

SF52 curtain wall systems

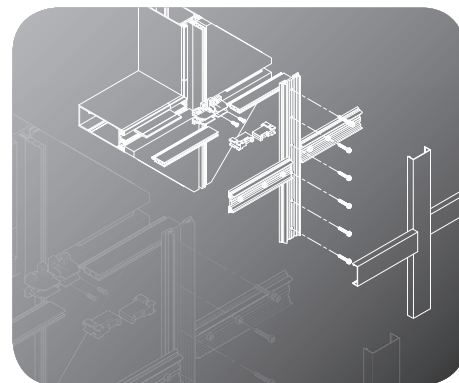

Scope

The SF52 curtain wall system has been designed to enhance thermal performance meaning the system can exceed current building regulations. It is a stick type front loaded system using spring pins and a specially designed cleat which allows square cutting throughout. The system can be either zone drained (via conventional pressure plate drainage or using a specially designed spout system) or it can be mullion drained. The zone drained system can be assembled capped, uncapped (using the SAS toggles) or combination of the two. Glazing ranges from 22mm to 50mm. Section sizes vary from 50mm to 250mm (50, 80, 100, 125, 150, 175, 200, 225, 250).

Materials

- All aluminium sections are extruded using Aluminium Alloy 6060, 6063 or 6083 (for improved strength) T6 to BS EN 755 part 9 2008 or BS EN 12020-2.
- Thermal breaks are extruded to BS 7619.
- Gaskets are manufactured in accordance with BS 3734.

Finishes

The SF52 curtain wall system is available typically in three finishes:

- Polyester Powder Coating to BS EN 12206-1: 2004 Part 1 – painted in house. Surface finish at 40 microns standard, or enhanced to 60 microns for marine environments, in accordance with ISO 9001, ISO 14001 and ISO 18001.
- Anodised finishes are to BS3897:1991 to a minimum of 25 microns (AA25), supplied in a limited range of colours.
- Mill finish.

Construction

The SF52 curtain wall system utilises square cuts throughout and is joined using a specially designed cleat and spring pin within the zone drained system. The mullion drained system uses a "lap" joint. A proprietary sealant is used on all metal to metal joints in line with good working practice. All internal gaskets are designed to mate with injection moulded corner pieces and are sealed at joints. Shear blocks and reinforcing sleeves are available.

SF52 curtain wall systems

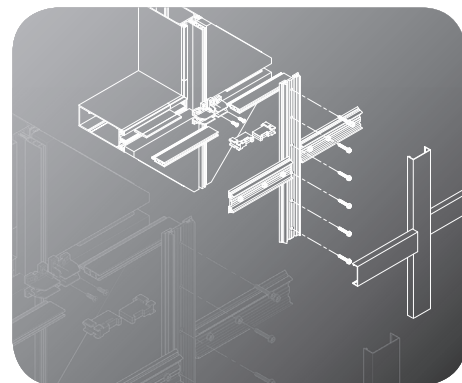

Technical Data

Weather rating

CWCT Sequence B

Air Permeability	600 Pa
Water Tightness	600 Pa
Wind Resistance	2400 Pa

EN13830:2003

Air Permeability	600 Pa
Water Tightness	600 Pa
Wind Resistance	2400 Pa

Glazing

Thickness	22mm - 50mm
-----------	-------------

Average U values

Due to the variety of profiles, mullion spacings, glass and panel specifications on each project; a specific U-value calculation will be required. Please contact our Technical Department.

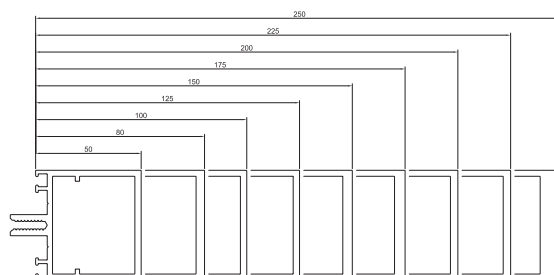

Environmental

SF52 curtain wall system when used on projects involved in a BREEAM assessment, or within the Code for a Sustainable Built Environment and the Code for Sustainable Homes (which therefore involves the Green Guide to specification) can offer significant benefits.

Specification.

Please contact our team for advice on product suitability, calculations and NBS or bespoke specifications.

All data in this specification sheet is courtesy of Senior Architectural Systems. Soundcraft Doors and Windows works in partnership with Senior Architectural Systems.

Soundcraft, Orchard Building, Hewitts Road, Orpington, Kent. BR6 7QL
T: 01959 533778 E: sales@soundcraft-doors.co.uk www.soundcraft-doors.co.uk

Soundcraft is a trading name of JKR Services Ltd. Registered Office: Chandler & Georges, 75 Westow Hill, London SE19 1TX. Registered No: 2201723

