

# Delta Membranes Damp Proofing

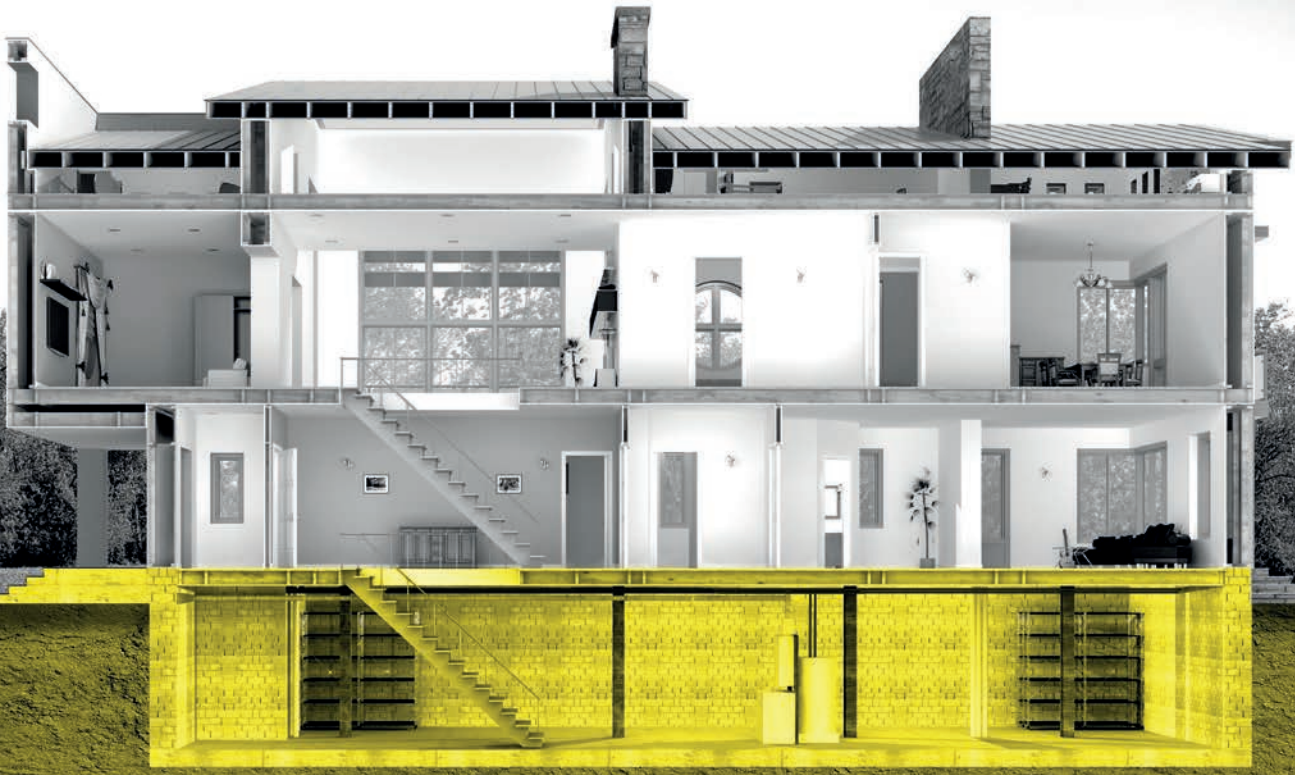

INNOVATION | MANUFACTURER | DESIGN | SOLUTION

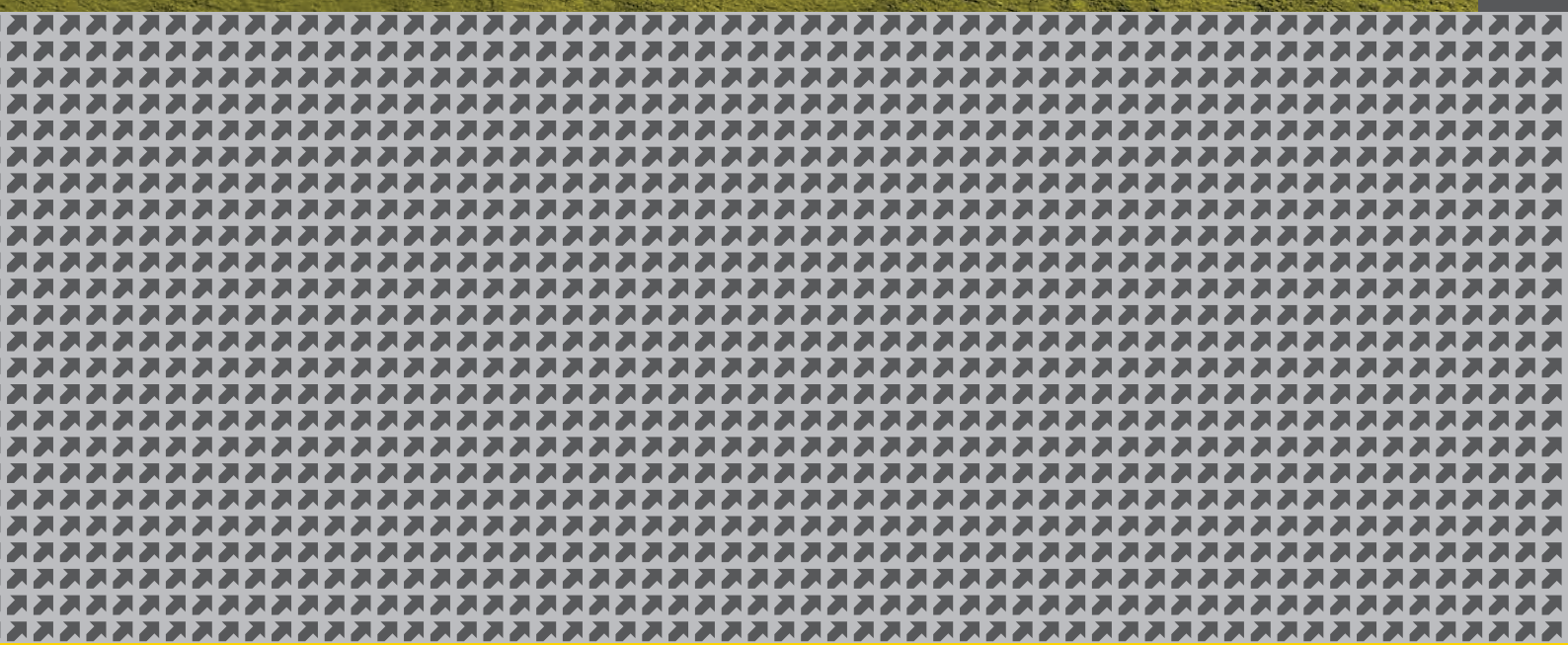

# CONTENTS



About Delta Membrane Systems Limited	3
Types of Damp	4
Standards	10
Design Philosophy	11
Heritage Structures	12
Barn Conversions	13
Gas Resistant Membranes & DPC's	14
Hygroscopic Salts	15
Products	16
Technical Drawings	33

## ABOUT US

# About Delta Membrane Systems Limited

Delta Membrane Systems Limited is a manufacturer and provider of specialist structural waterproofing solutions, covering Types A, B and C waterproofing, combination waterproofing, damp proofing, basement drainage, flood resilience and ground gas protection.

We aim to deliver excellence by putting our customers at the heart of everything we do.

Delta unites innovative products with highly skilled waterproofing design specialists. Our in-house team of technical consultants support our clients in providing comprehensive, reliable, and expert advice, identifying, and mitigating risk and establishing opportunities for added value.

Our projects include commercial and residential structures, new-build and refurbishment, housing developments and civil infrastructure. Our technical consultants cater to a diverse client base, including architects, developers, contractors, sub-contractors, engineers, and homeowners all centred on latest industry guidance, current legislation, standards, and best practice.

Delta proudly supports the Women of Waterproofing Networking Group. An independent networking group that promotes gender equality in the waterproofing sector, seeking to inspire, retain and attract females.

Delivering world-class solutions, Delta is an impeccable partner on every project.



## INNOVATION MANUFACTURER DESIGN SOLUTION



We have a dedicated, multi-disciplinary team creating, innovative, robust, and reliable waterproofing solutions. We strive for excellence and manufacturing synergy, utilising each team member's individual skills and own unique approach on design, collaborating to achieve exceptional results.



The Delta Specification team works with architects, designers, contractors, and engineers. Our team provides full consultation services, including CSSW Specification Reports. We offer advice on how Delta specifications can promote the successful outcome of any project.



With extensive experience in the field of structural waterproofing, we draw upon knowledge and expertise to offer totally flexible on-site support. As part of our commitment to innovate through the development of best practice, our on-site support will complement any existing design and installation team. We aim to help support and develop the skills of your technicians and, if required, will also provide bespoke onsite training for your technical teams.

# DAMP PROOFING

## Types of Damp

Structural waterproofing and damp proofing play a crucial role in preserving the structural integrity of buildings. Dampness, if left untreated, can significantly impact a building's solidity as water ingress may result in cracks in the masonry and deterioration of bricks and mortar. Furthermore, dampness can also alter the atmosphere within a building. Without proper intervention, a damp problem can escalate, leading to more severe issues. It's essential to note that various forms of dampness necessitate distinct treatment methods.

### RISING DAMP

Rising damp is a form of dampness that occurs when ground water rises-up through walls, floors and masonry via a capillary action (sometimes capillarity, capillary motion, capillary effect, or wicking) drawing moisture up through porous elements of a building's fabric. When water rises within the wall it will allow ground salts which are in solution to rise up the wall through capillary action, these salts are typically nitrate and chloride salts which are hygroscopic and actually attract moisture from the air. Ammonium Sulphates are often found in chimneys because of the burning of fossil fuels, these salts are also hygroscopic and classically why damp patches are often exhibited on chimney breasts.

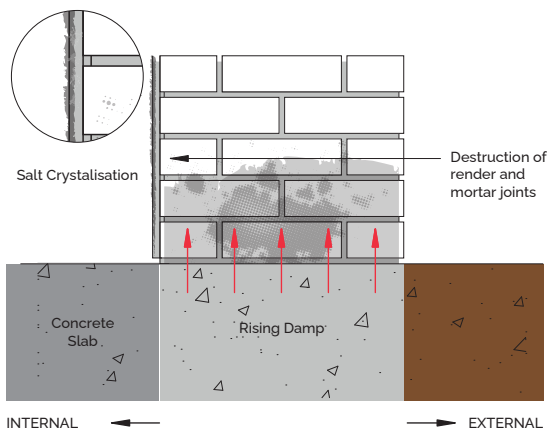

Rising damp is different to condensation, although has the same appearance.

The best example to explain how rising damp occurs is to imagine a sponge being dipped into water. The sponge sucks the water in. House bricks placed onto damp ground behave in an identical way, sucking up water from the wet ground. House bricks tend to suck water up, hence the name "rising damp". Bricks and masonry will continue to suck water up to around 1.2 metres (when gravity intervenes). The damp levels will continue to build up in these affected areas.

Much like the black mould found in condensation afflicted areas, the wet areas involved in rising damp also attracts mould spores, often the first sign that you have a rising damp problem. You may also notice damage to the outside of your home, rising damp offers a tell tale tide mark on exterior bricks.

### PENETRATING DAMP

Penetrating damp is moisture which penetrates laterally through the fabric of a building from the outside (typically because of leaking roofs, pipework, blocked or damaged guttering and cracks in walls).

Penetrating damp is particularly common in older buildings and south west facing walls.

Ground floor level walls can suffer from penetrating damp (a similar condition to rising damp). Common in cement rendered homes or those where a cavity wall has been filled. Penetrating damp is the result of trapped damp, or an increase in water vapour which overwhelms the few escape routes.

Dampness can be measured with electrical resistance meters or carbide meters, either on the surface or within the building fabric itself. A Calcium Carbide meter can be a fully accurate diagnostic tool especially when profiling is carried out, whilst salts analysis tests determine salt content of the fabric of the building also assisting in the diagnosis of rising damp.

Damp can be caused by problems within a home such as:

- Blocked or leaking gutters meaning rainwater enters a property
- Leaking pipes
- Broken pipes
- Issue with damp course

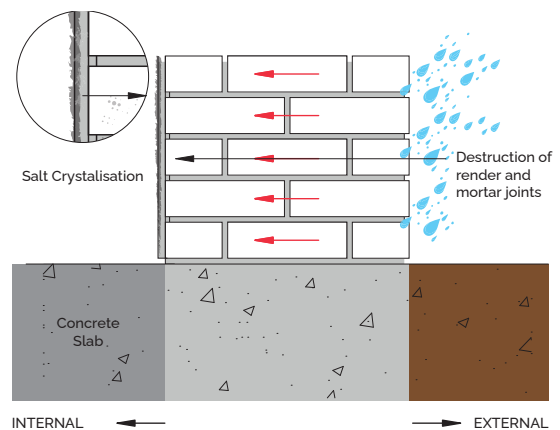



## ATMOSPHERIC MOISTURE IMBALANCE

Condensation and rising damp share similar characteristics which is one of the main reasons the two are often confused.

Condensation is formed from airborne moisture (atmospheric water) turning from water vapour to liquid. Naturally occurring there is always moisture in air. When air cools it is unable to hold moisture (water is heavier than air) meaning tiny droplets of water are formed. Condensation within the home is caused by changing temperatures. Water vapour constantly floats around your home and is innocuous. It is only when it meets something colder that it starts to become more troublesome.

When water vapour comes into contact with something cold, like a window or a poorly insulated surface, the water vapour drops in temperature and loses strength. It can no longer hold onto its water content and drops onto the colder surface. This recognisable deposit of water is what you see when you notice condensation. You can expect to see condensation on any surface where the temperature of the surface falls below the point that the air becomes saturated and no longer support water vapour. This is called the dew point which is the temperature at which it condenses. The dew point will vary based on temperature and how much water vapour is in the air. This is where the term relative humidity derives as the saturation point will change when the temperature increases or decreases.\* Windows and poorly insulated walls are the usual locations to expect condensation.

Condensation can lead to black mould, a naturally occurring fungus.



## DAMP PROOFING

Practices for a healthy, moisture-free environment.



## What is a Damp Proof Membrane?

Damp proof membranes, crafted from High Density Polyethylene (HDPE), serve as an effective barrier against moisture and salts. Once the root cause of dampness is addressed, these membranes are affixed to the interior walls. Utilising damp proof membranes is a beneficial method for damp proofing walls due to their easy installation and extreme flexibility. This flexibility allows the membranes to accommodate structural movement, guaranteeing long-lasting damp proofing that can span decades.

## What are DPC Solutions?

A Damp-proof course (DPC) is a protective barrier installed between a building and the ground to prevent moisture damage. The term refers to its purpose and function rather than the specific materials used. A high quality DPC is critical in preserving the integrity and health of any property. Chemical DPC solutions are particularly effective in managing rising damp issues both at ground level and above. These solutions consist of a concentrated, solvent-free synthetic resin designed to counteract capillary rising moisture in walls, irrespective of the moisture content and salt contamination. These chemical DPCs deeply permeate the smallest capillaries and pores of construction materials. Thanks to their exceptionally low density and surface tension, which is lower than that of water, they displace the water within the capillaries. The curing process of the injected product is not affected by the slow drying process of the masonry. Furthermore, chemical DPCs are durable, flexible, and do not decay, ensuring long-lasting protection

## What is liquid applied Epoxy?

Water Based Epoxy Resin is a versatile solution, ideal for any situations necessitating waterproofing or damp proofing for concrete or masonry. Its application process is essentially identical to standard emulsion paint, but with the added advantage of being usable in damp conditions. Upon drying, it forms a robust, non-toxic, waterproof surface that is effortless to maintain. For optimal outcomes, it's recommended that surfaces are stripped of any existing coatings before application of a water-based epoxy resin.

Before the application of any products, it's essential to remove any greasy film to establish a reliable base. It is crucial to meticulously fill any voids, holes, and gaps.

## Restoration Plaster

Restoration Plasters serve a unique purpose. They are typically used when masonry is slightly damp, as they can aid in drying the wall and prevent further damage. The advantage of Restoration Plaster is that it allows the masonry to dry, thereby preventing additional harm.

Restoration plasters, specifically formulated to handle high salt and moisture levels, are essential for the refurbishment of masonry. These plasters remain unaffected by elevated salt quantities, successfully stopping salts from reaching the wall surface. Additionally, they play a crucial role in drying out damp-affected walls while also absorbing residual salts. These plasters, unique in their composition, lack lime or gypsum, allowing them to resist moist environments effectively. They permit water vapour diffusion, contributing to a healthier, more comfortable indoor atmosphere.

## Ventilation / Humidity Control:

In order to manage condensation problems, it's critical to regulate the internal moisture in a structure. This can be achieved through various methods. Installing air vents and air bricks, employing passive ventilation, and utilizing other mechanical humidity control strategies are all viable options. These measures should be integrated into a comprehensive solution to effectively combat condensation issues.

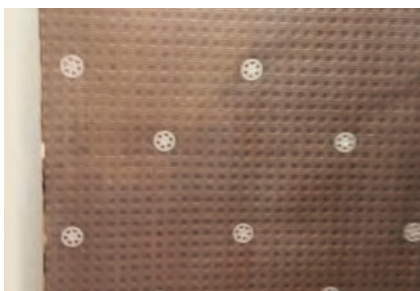

# DAMP PROOFING

## Types of Damp Proofing

### DAMP PROOF MEMBRANE

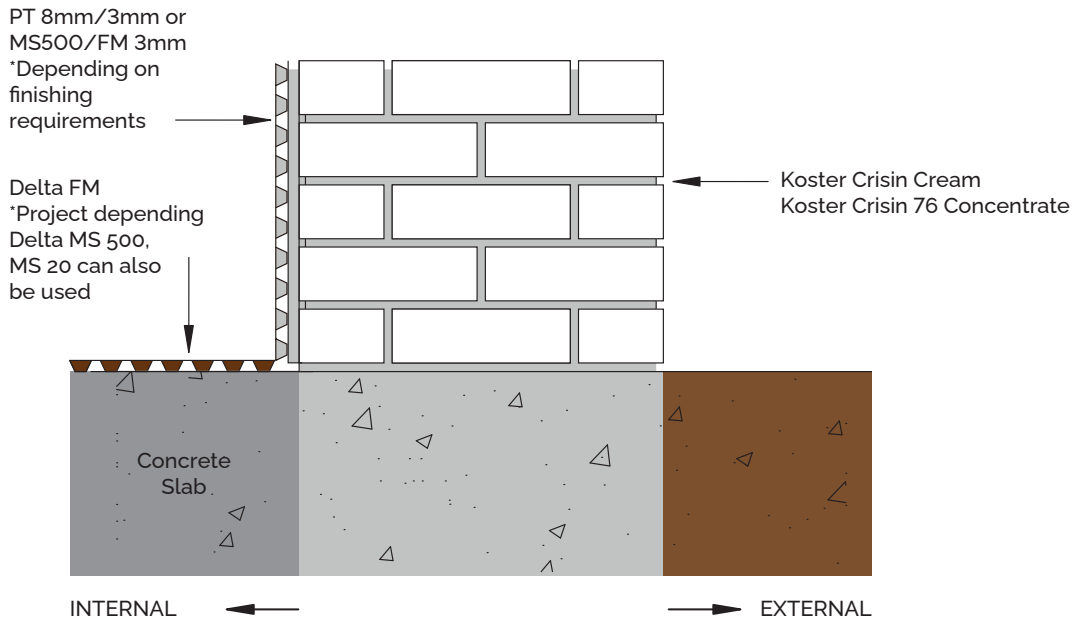

### MASONRY PROTECTION CREAM

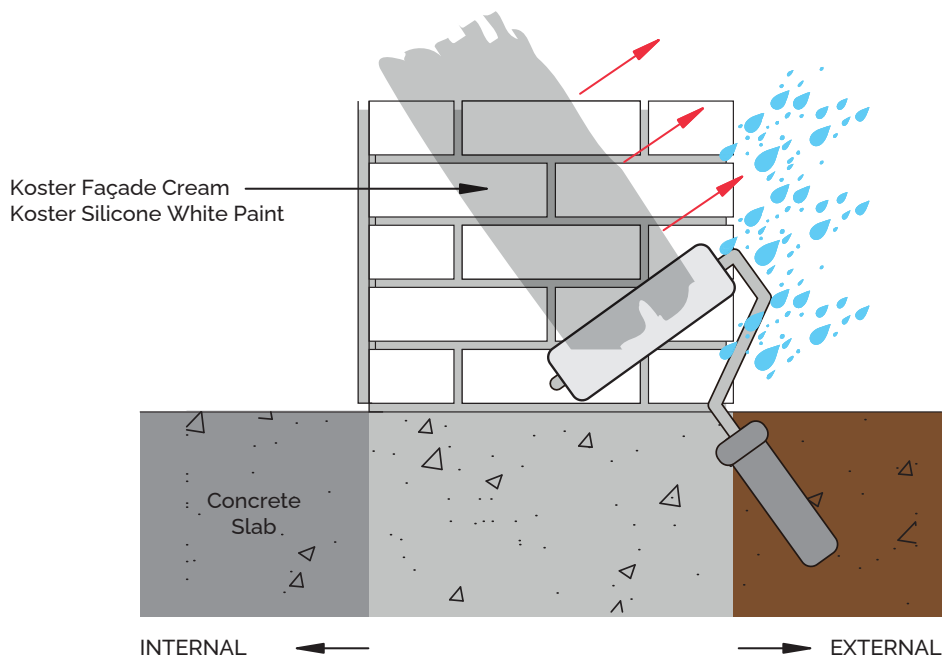



## DPC

Damp Proof Membrane (DPM) taped to DPC or brought up to DPC Level  
DPC should be built into the wall.

The DPM should be brought up to the level of the DPC but should not fold into the wall.

Delta Gas Barrier DPM

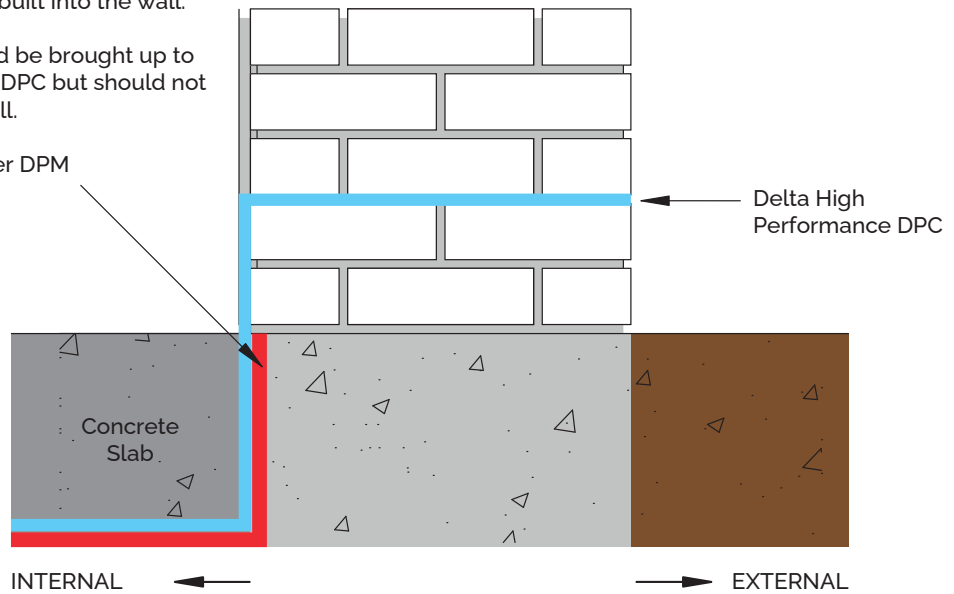

## RADON PROTECTION MEMBRANE/DPC

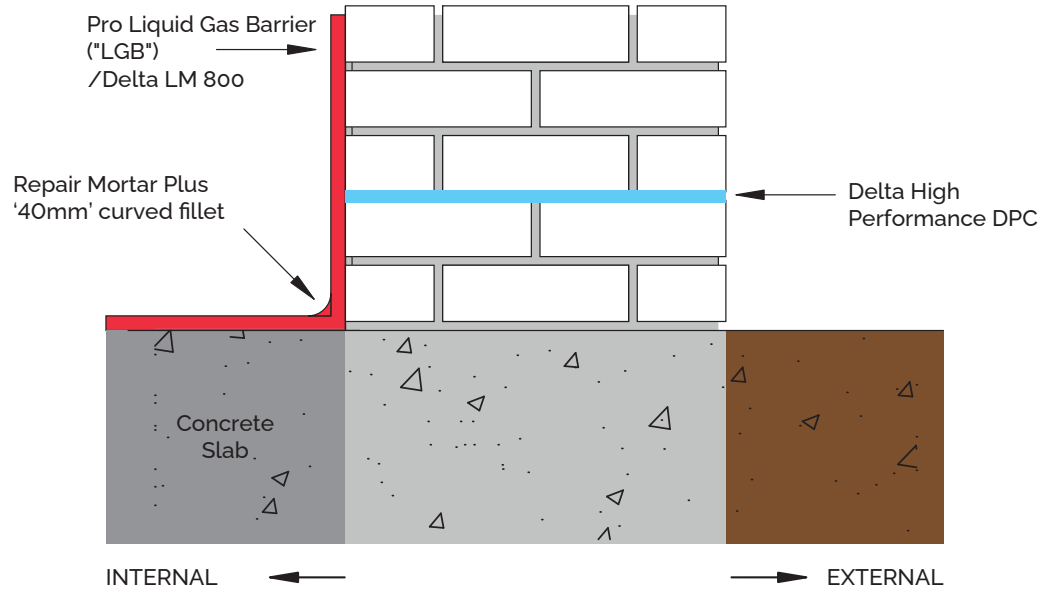

# DAMP PROOFING Standards

## British Standards

The BSI Group, originally known as the Engineering Standards Committee, was founded in 1901 with the principal aim of standardising the steel produced in Great Britain. The purpose was to enhance both competitiveness and efficiency. Over the years, these standards have been expanded to incorporate various facets of the engineering and building industry. These include engineering methodologies, quality norms, safety measures, system standards, and security protocols. This comprehensive standard framework continues to evolve, ensuring the industry adheres to best practices.

## Damp Proofing Standards

Damp Proofing Standards are incredibly important within the Damp proofing scope, from investigation to diagnosis to control of dampness in structures.

- BS 6576:2005+A1:2012 Code of Practice for Diagnosis of Rising Damp in Walls of Buildings and Installation of Chemical Damp Proof Courses
- BS 5250:2021 Management of Moisture in Buildings. Code of Practice
- BS 8104:1992 Code of Practice for Assessing Exposure of Walls to Wind-Driven Rain
- BS 8215:1991 Code of Practice for Design and Installation of Damp-Proof Courses in Masonry Construction

BS 6576:2005+A1:2012 covers (but is not limited to):

- Building Assessments
- Inspection Procedures
- How to diagnose and treat rising damp
- Pre-installation measures
- How to install a damp-proof course
- The need to differentiate between rising damp and other causes of damp conditions
- Gives recommendations for the chemical treatment of rising damp in existing buildings with solid walls, cavity walls (unfilled or filled) and random rubble-filled walls
- Essential precautions and procedures for installing chemical damp-proof courses are also indicated
- Finishes

Knowing how to recognise the type of damp as well as treat damp is essential when specifying a remedial approach. Damp can damage much more than a structures appearance. If untreated, damp may lead to the deterioration of masonry, plaster and promote timber decay whilst creating unhealthy conditions for occupants.

Delta unites innovative products with highly skilled waterproofing design specialists. Our in-house team of technical consultants support our clients in providing comprehensive, reliable, and expert advice, identifying, and mitigating risk and establishing opportunities for added value.

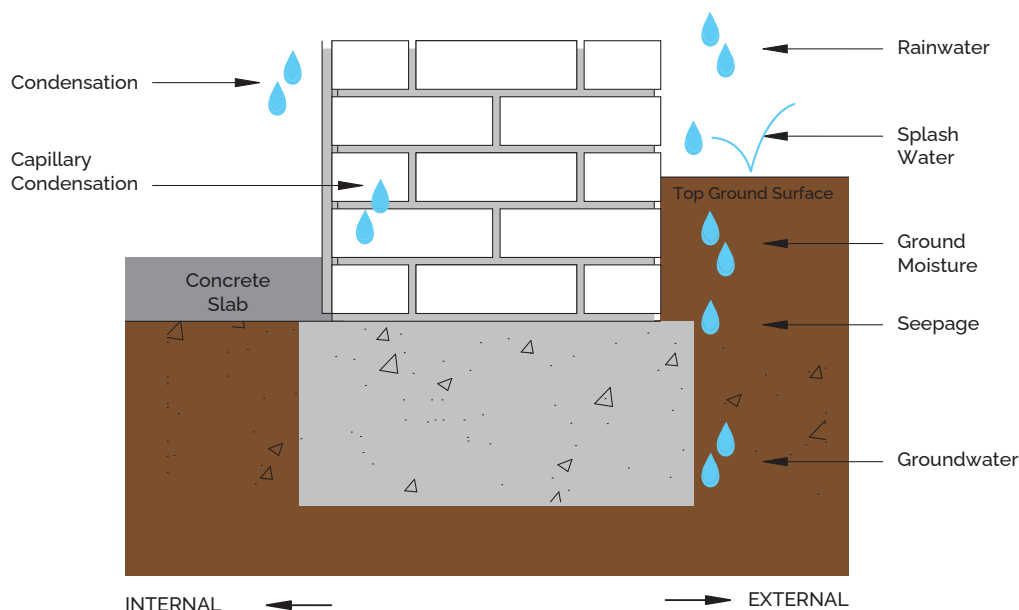

# DAMP PROOFING

## Design Philosophy

Porous materials in a 'dry' building surprisingly contain a significant amount of water, which mostly causes no damage. The designation of a building as 'damp' only applies if moisture manifests visibly, indicated by discolouration, staining, mould growth, sulphate attack, frost damage, or the presence of drips and puddles. These symptoms can result in the degradation of decorations and the structural integrity of the building.

The common indicators of dampness, such as peeling paint or wallpaper, remain consistent irrespective of the dampness origin. Nevertheless, the treatment method varies based on the cause of the dampness, making it crucial to accurately identify the source before initiating any remedial measures.

Moisture within buildings can originate from multiple sources, resulting in an intricate issue. The presence of moisture, manifested through phenomena like penetrating damp, rising damp, and condensation, may appear alike. However, each of these conditions necessitates a unique damp-proofing method to rectify the problem effectively.

In a professional context, we focus on accurately identifying issues related to dampness. It's an intricate process that requires thorough understanding and expert analysis for precise diagnosis.

When implementing any damp proof system, it's imperative that installers inform property owners about potential risks and hazards that may arise from the damp proof remediation process. They also need to be cognizant of their responsibilities in compliance with health and safety regulations. Furthermore, it's important to verify that property owners have secured necessary permissions, especially when the walls to be treated are shared with neighbouring properties, often referred to as party walls.

### Choice of Materials

There are several choices of materials available to treat dampness:

- Damp proof membranes
- DPC solutions
- Liquid applied Epoxy
- Restoration Plasters
- Ventilation / Humidity control



Damp Proof Membranes



DPC Solutions

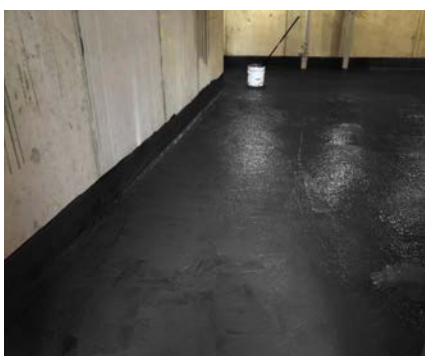

Liquid Applied Epoxy



Restoration Plasters



Ventilation

# DAMP PROOFING

## Heritage Structures

### Heritage Structures/Listed Buildings

When designing a damp proofing solution in a historic building or structure of architectural interest, additional attention needs administering during the design stage to maintain the aesthetic and structural integrity of the structure/building. The design should offer a sympathetic and holistic approach.

Determining how the building envelope operates gives a clear picture on the best method for remedial solution. How the exterior and interior interact with environments and these functional purposes must be understood to not endanger the operation of the envelope.

#### Every building and structure's envelope is unique.

Delta's Damp Proofing System (PT/MS 500) is a widely adopted solution in numerous heritage sites across the United Kingdom, thanks to its respectful approach. This system employs an 'air gap' technology, which has gained considerable approval from notable institutions such as English Heritage, The Society for Protection of Ancient Buildings (SPAB), and local authority conservation officers. This broad acceptance underscores the system's effectiveness in preserving the integrity of historical structures.

The Delta System is designed with a focus on preservation, hence, it requires no harsh preparation that could potentially harm historical or heritage structures. Its unique feature is its reversibility, allowing for effortless removal whenever necessary. Importantly, the underlying structure remains untouched and preserved, ensuring the integrity of the original design.

The Delta System is not intended to serve as a substitute for lime render. It is designed as an alternative solution for special cases where lime renders fail to perform efficiently. These scenarios could include below-ground structures, buildings with high salt contamination, or structures that cannot be effectively repaired or sufficiently waterproofed from the exterior. This might be the case were certain architectural features are unalterable. The Delta System presents a remedial approach to these specific challenges.





## DAMP PROOFING

# Barn Conversions

### Barn Conversions

As a result of changes in general farming practice, many barns and agricultural structures have become redundant for agricultural use allowing many to be converted for other uses.

A common problem experienced in barn conversion projects for residential use is damp and salt contamination.

Barns originally had only been designed for agricultural use, often there is little, or no damp proofing installed during construction. Floors and walls to barns also experience salt contamination, particularly if the barn was used to house livestock.

These salts after often hygroscopic which mean they attract moisture from the atmosphere and unless treated will continue attracting moisture from the atmosphere. Typical of the building era, barns are constructed from a range of materials from cob to various types of stone depending on locality. Every building and structure's envelope is unique and will require its own unique damp proofing solution.

Restoration Plasters are classed as salt encapsulating hydrophobic plasters. They can store mineral salts within their "open cell" structure and prevent them from causing surface damage or spoiling of finishes. Koster Restoration Plasters do not contain Gypsum or lime. It also serves to improve the insulative properties of a wall by creating a bridge between the cold wall and the internal environment thereby aiding and reducing the risk of condensate forming on its surface. Restoration plasters can be used internally or externally and for a plaster, exhibit a good compressive and tensile strength. When used on its own, the Koster Restoration Plaster Grey or White finish is an "open pored" texture (Similar to an external render). If this is not desired, then the Koster Restoration Plaster system can be used to smooth the surface. Delta's Cavity Drainage Membranes are also a popular solution.





## DAMP PROOFING

# Gas Resistant Membranes and DPC's

Gas membranes (ground gas protection systems) can provide a barrier against harmful ground gases such as radon, methane and carbon dioxide whilst also acting as a damp proof membrane, protecting a property not only from ground gases but also from moisture ingress.

### RADON

Radon occurs naturally in the environment, this radioactive gas is, colourless, odourless and tasteless. Radon can migrate into any building that is built over a source. If it accumulates in a building, it increases the risk of lung cancer for occupants. Radon is the cause of 15% of lung cancers worldwide (World Health Organisation 'WHO' 2009).

Gas protection is a technical solution to prevent or to control gas penetration into properties. The control of gas migration is normally achieved by blocking the pathway or removing the source of the gas generation. There are several methods available to achieve the protection to existing and new build properties.

In areas where radon gas is found at higher levels (the average level of Radon in UK homes is 20 Bq m<sup>-3</sup>. For levels below 100 Bq m<sup>-3</sup>, individual risk remains relatively low and not a cause for concern. However, the risk to health increases as radon levels increase.), it is important that radon barriers are used to prevent this killer gas from seeping into the building and harming occupants. Radon barrier membranes and Radon DPCs prevent gases entering a property.

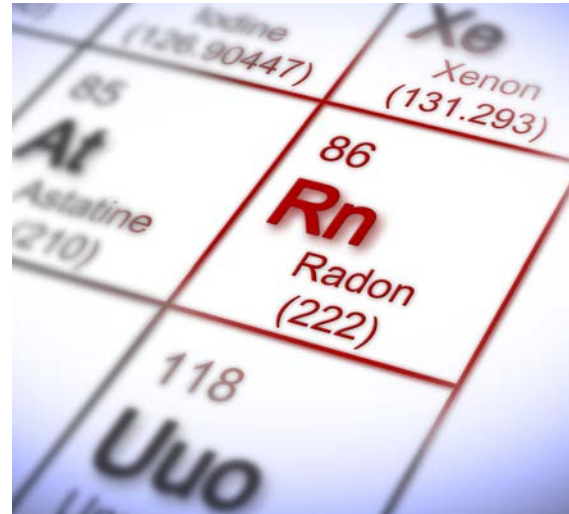

Radon is estimated to cause between 3-14% of lung cancers in a country

(World Health Organisation 'WHO' 2021)



## DAMP PROOFING

# Hygroscopic Salts

### HYGROSCOPIC SALTS

The term 'hygroscopic' tends to refer to "absorbing", a substance which is classed as hygroscopic is one which can attract and absorb moisture. When dampness has been rising up a wall for a period, the soluble salts (mainly chloride and nitrates), normally found in the ground become concentrated where water has evaporated. These deposits of salts are hygroscopic and deliquescent, and they will continue to attract the everyday moisture found in buildings and structures. Even after a functioning rising damp barrier has been installed, these salts can still absorb residual moisture in the wall or from the room itself. Salt crystal growth at the wall surface causes the breakdown of decorative finishes and will feel damp to the touch.

This 'dampness' is not caused by water rising up through the capillaries of the wall, but due to the dampness in the wall itself evaporating to leave marks. Concentrations of chloride or nitrate salts may increase to as much as 1-2% in walls that have been affected by rising dampness. Uncontaminated building materials usually have a concentrate of less than 0.01%. If left untreated hygroscopic salts can lead to continuous problems in structures. Residue hygroscopic salts are usually removed from a structure by removal of the salt contaminated plaster and re-plastering with a salt resistant restoration plaster. Removing salt contaminated plaster alone will not remove the salt accumulated within the masonry itself. If re-plastering is not carried out with salt resistant restoration plaster, both remaining residual water and hygroscopic salts will migrate through the surface finishing over time and with a higher level of intensity.

If left untreated hygroscopic salts can lead to continuous problems in structures.





# DAMP PROOFING

## Delta PT (including Delta PT/Plaster Lath)

Delta PT is an 8mm studded Type C, Cavity Drainage Membrane that is suitable for use in basement waterproofing for new and existing structures.

Delta PT can also be used in above ground application to provide a damp proof barrier and to isolate plaster finishes from contamination. Delta PT is a High-Density Polyethylene (HDPE) 8mm studded membrane with a heat welded polypropylene mesh.

Delta PT is suitable as an impermeable damp proofing base for plaster or shotcrete (with suitable reinforcement) and as a water control and drainage membrane in tunnel construction or for remedial damp proofing and waterproofing of existing basements internally.

### Features

- 8mm studded profile
- BBA Approved
- Drainage capacity 5 L/s m<sup>2</sup>
- Compressive Strength: 70 KN/m<sup>2</sup>
- An effective barrier to the transmission of salts, liquid water and water vapour
- A "reversible" system, which will minimise damage to historical or heritage structures
- Resistant to chemicals, root penetration, rotproof, neutral towards drinking water

### Durability

Subject to normal conditions, Delta PT will provide an effective barrier to the transmission of water, water vapour and salts, for the life cycle of the structure.

### Fields of Application

- Used in new build construction and retrofit projects
- As protection for high quality floor finishes such as hardwood
- As protection for floor finishes such as screeds
- Air gap damp proofing membrane
- Creates a continuous air gap in substrates
- Damp pressure equalisation and ventilation
- Zero "down time" in fast track installation
- Excellent for detailing existing staircases and tight spaces
- Can be linked to other Delta Type C Membranes

### Specification

- BS 8102:2022 Protection of below ground structures against water ingress. Code of practice.
- BS 6576:2005+A1:2012 Code of Practice for Diagnosis of Rising Damp in Walls of Buildings and Installation of Chemical Damp Proof Courses
- J40/290 High-density polyethylene/ polypropylene studded cavity drain membrane



### Technical data

DMS	001/002
Material	High Density Polyethylene (HDPE)
Compressive Strength	70 KN/m <sup>2</sup>
Stud Height	8mm
Roll Size	1.5m x 10m and 2m x 20m
Drainage Capacity	5 L/s m <sup>2</sup>
Temperature Resistance	-30°C to +80°C
Reaction to Fire	EN13501-1 Class E

### Product details

DMS 001 1.5m x 10m

DMS 002 2m x 20m

### Associated Products

- Delta PT Plugs
- Delta Flexi Dri Plus Plugs
- Delta Ultra Fix Plugs
- Delta Cornerstrip
- Delta Sealing Tape
- PT Profile Strip



# DAMP PROOFING

## Delta FM

Delta FM is a Virgin High-Performance PE-VHD. Specifically designed for floor applications to combat capillary dampness and contamination.

The low stud profile (4 mm) minimises the impact upon existing floor levels but still provides an air gap to achieve damp pressure equalisation. The special low profile offered by Delta FM is excellent for detailing existing staircases and tight spaces. Delta FM can be linked to other Delta Type C, cavity drainage membranes. A fast-track application which allows for various floor finishes to be achieved with zero 'down time'.

Delta FM can be used in new build, remedial or refurbishment projects.

### Features

- 4mm studded profile
- Suitable for use on damp proofing walls, floors, and vaulting ceilings
- Compressive Strength: 700 kN/m<sup>2</sup>
- Fast track installation
- Durable, puncture and impact resistant
- Resistance to water, water vapour & salt transfer
- Suitable for floors

### Durability

Subject to normal conditions, Delta FM will provide an effective barrier to the transmission of moisture for the life cycle of the structure.

### Fields of Application

- Used in new build construction and retrofit projects
- As protection for high quality floor finishes such as hardwood
- As protection for floor finishes such as screeds
- Air gap damp proofing membrane
- Creates a continuous air gap in substrates
- Damp pressure equalisation and ventilation
- Zero "down time" in fast track installation
- Excellent for detailing existing staircases and tight spaces
- Can be linked to other Delta Type C Membranes
- 

### Specification

- BS 8102:2022 Protection of below ground structures against water ingress. Code of practice.
- J40/290 High-density polyethylene/ polypropylene studded cavity drain membrane
- J40/47 High-density polyethylene/ polypropylene studded cavity drain membrane
- Classification Pr\_25\_57\_51\_74



### Technical data

DMS	023
Material	Virgin high-performance PE-VHD
Material Application	Special low stud profile for floor. Can be used on walls.
Sheet Thickness	0.6mm
Stud Height	4mm
Roll Size	2m x 20m
Compressive Strength	700 kN/m <sup>2</sup>
Air Volume Between Studs	2.6 L/m <sup>2</sup>
Temperature Resistance	-30°C to +80°C
Reaction to Fire	EN13501-1 Class E

### Product details

DMS 023

### Associated Products

- Delta Cornerstrip
- Delta Sealing Tape
- Delta Perimeter Drainage Channel
- Delta Basement Drainage Systems
- Delta MS 500



# DAMP PROOFING

## Delta PT 3mm Mesh

Delta PT 3mm mesh membrane has been developed specifically for addressing the issues of damp and contaminated walls, or where fast reinstatement of wall finishes is required after chemical damp proof injection.

Delta PT 3mm a High-Density Polyethylene (HDPE) low profile studded membrane with a heat welded polypropylene mesh provides a key for plaster, renders or dab fix of plaster boards.

Delta PT 3mm is impervious to moisture and moisture vapour creating a new barrier between old surfaces and new internal finishes. Delta PT 3mm effectively isolates damp walls and will prevent any new salts to deposit on surface plasters and decoration.

### Features

- 3mm studded profile
- BBA Approved
- Drainage capacity 2 l/s m<sup>2</sup>
- Air Volume between studs 2 l/s m<sup>2</sup>
- An effective barrier to the transmission of salts, liquid water and water vapour
- Provides key for plaster, renders or dab fix
- Resistant to chemicals, root penetration, rotproof and neutral towards drinking water

### Durability

Subject to normal conditions, Delta FM will provide an effective barrier to the transmission of moisture for the life cycle of the structure.

### Fields of Application

- Suitable for damp proofing
- Provides an excellent key for plaster, renders or dab fix
- Controls damp, salts and isolates other wall contaminants
- An effective barrier to the transmission of salts, liquid water and water vapour
- Suitable for new, existing, and retrofit projects including barn conversions

### Specification

- BS 8102:2022 Protection of below ground structures against water ingress. Code of practice.
- BS 6576:2005+A1:2012 Code of Practice for Diagnosis of Rising Damp in Walls of Buildings and Installation of Chemical Damp Proof Courses
- J40/290 High-density polyethylene/ polypropylene studded cavity drain membrane
- J40/47 High-density polyethylene/ polypropylene studded cavity drain membrane
- Classification Pr\_25\_57\_51\_74



### Technical data

Delta PT	
DMS	030/027
Material	High Density Polyethylene (HDPE)
Sheet Thickness	0.4mm
Stud Height	3mm
Roll Size	1m x 20m 2m x 20m
Air Volume Between Studs	2 l/m <sup>2</sup>
Temperature Resistance	-30°C to +80°C
Reaction to Fire	EN13501-1 Class E

### Product details

DMS 030 1m x 20m  
DMS 027 2m x 20m

### Associated Products

- Delta Qwikseal Plugs
- Delta PT Plugs
- Delta Ultra Fix Plugs
- Delta Sealing Tape
- Delta Cornerstrip
- Delta LM 800





## DAMP PROOFING

# Delta High Performance DPC

Delta High Performance DPC is a high-performance, flexible polymeric sheet material designed to suit all applications to prevent passage of moisture from the ground and at all levels as cavity tray to prevent the downward movement of water. Available in various widths either for use in buildings up to four storeys or for use in buildings in excess of four storeys.

### Features

- Low permeability
- Flexible
- Extremely robust
- Can be used in vertical, horizontal, stepped and cavity tray application
- Available in various thickness's
- Excellent tear resistance under high compressive loads
- Both faces feature a non-slip profile to ensure optimum mortar adhesion
- Bitumen-compatible, rot-proof and UV-stabilized
- Highly flexible even at low temperatures, so that no cracks will occur in the material

### Fields of Application

- Suitable for use as a DPC in all types of building construction
- Effective barrier to rising damp and moisture
- As a general waterproofing and decorative finish for all brick, concrete, cement, and masonry surfaces
- Effectively installed into masonry to form a damp-proof course or cavity tray

### Specification

- F30 Accessories/sundry items for brick/block/stone walling 360 Gas Resistant DPCs/Cavity Trays
- BS6515:1984 Specification for polyethylene damp proof courses for masonry



### Technical data

DMS	300 (100mm x 20m) 301 (150mm x 20m) 303 (300mm x 20m) 304 (450mm x 20m) 305 (600mm x 20m) 348 (1000mm x 20m)
Tensile Strength	BS 2782 m320a (100mm/min) MD-12.9N/mm <sup>2</sup> /TD-11.2N/mm <sup>2</sup>
Elongation at Break	BS 2782 m320a (100mm/min) MD-415%/TD-582%
Tear Strength	BBA Method (Supersedes BS 2782 m260b:1980) MD-122N/mm <sup>2</sup> /TD-96N/mm <sup>2</sup>
Water Absorption	BS 2782 M430A (after 7 days) 0.22%
Water Vapour Transmission	BS 3177 (75% RH 25°C) 733MNs <sup>g</sup> -1
Low Temperature Flexibility	BS 2782 M150B MOAT 27: 5.4.2 -25°C



# DAMP PROOFING

## Gas Barrier DPM

Delta Gas Barrier DPM provides permanent protection from Radon (RN) Gas whilst forming a protection layer against rising damp.

Radon is a colourless, odourless, radioactive gas that comes from rocks and soil. Radon levels are higher inside buildings compared to outside, and exposure to the gas over an extended period of time can be harmful to occupants.

Delta Gas Barrier has an anti-slip profile on both sides which stabilises the sheet and optimises adhesion to mortars.

### Features

- Resistant to Radon ground gas
- Extremely durable and tear-resistant
- Special polyolefin blend forming a sheet approx. 0.4 mm thick
- Flexible and easy to install
- Resistant to extreme temperatures
- UV-stabilized
- Long-term protection
- Resistant to chemicals, root penetration, rotproof

### Durability

Subject to normal conditions, Delta Gas Barrier will provide an effective barrier to Radon Ground Gases for the life of the building.

### Fields of Application

- Suitable for use on sites with radon gas
- Protects against moisture, acting as a damp-proof membrane (DPM)s
- Suitable for horizontal applications
- For foundations and building walls

### Specification

- D21/350 Gas-retardant membrane
- F30/360 Gas-resistant damp-proof courses/cavity trays
- F30/54 Gas-resistant dpcs/cavity trays
- J40/140 Loose-laid plastics or rubber sheet gas-retardant membranes
- J40/35 Loose-laid plastics or rubber gas-retardant membranes
- Q37/320 Root barrier
- Q37/355 Combined layers
- Pr\_25\_57\_65\_60
- BR 211 – 2023-Radon – Protective measures for new buildings.



### Product details

DMS 119

### Associated Products

- Delta Cornerstrip
- Delta Sealing Tape
- Delta Sealing Rope
- Gas Tape 50
- Gas Over Tape 150
- Delta LM 800



## Technical Details

Delta Gas Barrier DPM			
Characteristics	Methods	Values	Units
Application	-	Plastic damp proof course and gas barrier for building constructions against rising humidity, gas like radon etc.	-
Material	-	LDPE	-
Colour	-	Black	-
Surfaces	-	Both faces features a non-slip profile to ensure also optimum mortar adhesion.	-
Properties	-	Bitumen compatible, root-proof and UV-stabilized. Highly flexible even at low temperatures, so that no cracks will occur in the material. Being relatively thin, strips will come off the roll quickly and are easy to work with.	-
Weight	EN 1849-2	Approx. 280	g/m <sup>2</sup>
Thickness	EN 1849-2	Approx. 0.4	mm
Transmission Properties	Methods	Values	Units
Sd-value	EN ISO 12572	95	m
Water Vapour Transmission	-	2.05 · 10 <sup>-12</sup>	kg/m <sup>2</sup> .s.Pa
Resistance Against Water Vapour Diffusion $\mu$	-	185.000	-
Radon Permeability k	-	20 · 10 <sup>-12</sup>	m <sup>2</sup> /s
Radon Transmittance	-	50 · 10 <sup>9</sup>	m/s
Radon Flow Rate P	-	Approx. 0.0025	Bq/(m <sup>2</sup> .s)
Mechanical Properties	Methods	Values	Units
Tensile Strength MD/CD	EN 12311-1	Approx. 250/160 (±10%)	N/5 cm
Resistance to Tearing MD/CD	EN 12310-1	> 80 / 80 N	N
Water Column	-	4 m, 72 hours	-
Watertightness	EN 1928	Watertight (2 kPa / 24 hours)	-
Watertightness after artificial ageing by longterm exposure to elevated temperature	EN 1928 EN 1296	Watertight (2 kPa / 24 hours), ageing 12 weeks 70°C	-
Watertightness after exposure in alkaline environment	EN 1928 EN 14909	Passed	-
Resistance to folding at low temperatures	EN 495-5	≤ -20	°C
Resistance to Impact	EN 12691	≥ 150	mm
Other Properties	Methods	Values	Units
Reaction to Fire	EN 13501-1	E	-
Temperature Range	-	-30 à +80	°C
CE Conformity	EN 14909	Yes	-
Roll Dimension	-	4 x 25	m

# DAMP PROOFING

## Pro Liquid Gas Barrier "LGB"

Pro Liquid Gas Barrier ("LGB") is a multi-use synthetic rubber-based gas protection and waterproofing system.

Pro LGB offers a simple, continuous passive gas prevention barrier against the ingress of methane, carbon dioxide, radon, ground gas, VOC, air and moisture into buildings. Pro LGB also acts as a waterproofing membrane complying with the requirement C2 and C4 schedule 1 of the Building Regulations 1991 for England and Wales.

Pro LGB is an elastic, UV-resistant, single component system supplied in black. This non-hazardous product can be applied direct from its packaging using a roller, brush or airless spray. Pro LGB can be applied to damp or dry substrates and dries in approximately 1 hour to form a tough semi-gloss finish.



### Features

- Methane, Carbon Dioxide and hydrocarbon vapour suppression
- Dual use – damp or waterproof gas barrier
- Excellent bonding strength
- Good resistance to Alkali and brine solution
- Resistant to weak mineral acids
- Damp surface tolerant
- Quick drying

### Specification

- BS 8485:2015+A1:2019 Code of practice for the design of protective measures for methane and carbon dioxide ground gases for new buildings
- BS 8102:2022 Protection of below ground structures against water ingress. Code of practice.
- NBS Specification J30 Liquid Applied Tanking/Damp Proofing

### Product details

DMS 405

### Associated Products

- Koster NB 1
- Delta AT 800
- Pro M1
- Pro R1
- Gas Over Tape 150

### Technical data

Pro Liquid Gas Barrier			
Feature	Characteristics	Test Method	Pro Liquid Gas Barrier
Physical Properties	Density	-	1.5-1.6 g/cm <sup>3</sup> at 20°C
	Form Supplied	-	Viscous Liquid
	Pack Size	-	15kg (Bespoke sizes available on request)
	Colour	-	Black
	Shelf Life	-	18 months (unopened)
	Odour	-	Latex (Vanilla)
	Drying Time	-	1 hour at 20°C
Permeability*	Water Vapour Permeability	-	<0.5 g/m <sup>2</sup> /day
	Methane Permeability	EN ISO 15105-1	<28.8ml/m <sup>2</sup> /day/atm
	Carbon Dioxide Permeability	EN ISO 15105-1	<267ml/m <sup>2</sup> /day/atm
	Radon Permeability	K124/02/95	<9.5x10 <sup>12</sup> m <sup>2</sup> /s
Hydraulic Properties	Water Tightness (60 kPa)	EN 1928	PASS (Watertight at 0.6mm thick)



# DAMP PROOFING

## Pro R1

Pro R1 Gas Barrier is a flexible, loose laid proprietary gas barrier for sites with Radon (RN) ground gas.

Pro R1 is a low-density polyethylene membrane with reinforced polypropylene reinforcing grid. This specifically designed membrane is suitable as a high-performance damp proof membrane, radon, air and moisture protection system as well as a low-level protection to carbon dioxide and methane.

Pro R1 is sufficiently resistant to the ingress of harmful gases into a building. Pro R1 can be used on any site where low levels of ground gas is present up to and including CIRIA 665 Situation 2. On more heavily contaminated sites a passive or active venting system may be required to dilute the gases down to acceptable levels and specific design advice should be sought.

### Features

- High quality membrane
- Tough, durable design
- Conforms with latest codes of practice as published by BRE, CIRIA and BSI
- Heat welded or taped, with jointing carried out by competent personnel with suitable qualifications in accordance with best practice
- Suitable for new build and refurbishment projects
- Low permeability to carbon dioxide, methane and radon

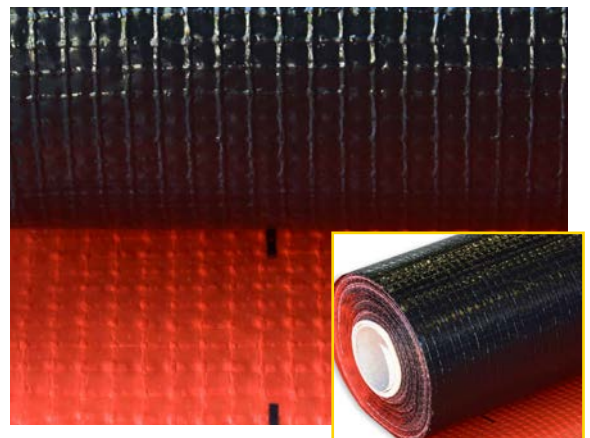

### Specification

- NBS Specification J40 Flexible waterproofing/damp proofing membrane including Radon protection
- NBS Specification J40/145 Loose laid weldable polyethylene gas retardant damp proofing

### Product details

DMS 401

### Associated Products

- Koster NB 1
- Delta AT 800
- Pro M1
- Gas Over Tape 150



### Technical data

PRO R1			
Feature	Characteristics	Test Methods	Pro R1
Physical Properties	Thickness	EN 1849-2	0.5mm
	Width	EN 1849-2	Various m
	Length	EN 1849-2	Various m
	Weight	EN 1849-2	275g/m <sup>2</sup>
Hydraulic Press	Water Column	EN 20811	Pass
	Resistance to Water Penetration	EN 13967, EN 1928	Pass
	Water Tightness	EN 11296, EN 1367, EN 1928	Pass
Mechanical Properties	Resistance to Static Load	EN 12730-B	20kg
	Tensile Strength (MD)	EN 12311-1	500N/50mm
	Tensile Strength (CMD)	EN 12311-1	470N/50mm
	Tensile Elongation (MD)	EN 12310-1	15%
	Tensile Elongation (CMD)	EN 12310-1	20%
	Puncture Resistance	EN 12236	1.04 kN
	Resistance to Tearing (Nail Shank) MD	EN 12310-1	400N
	Resistance to Tearing (Nail Shank) CMD	EN 12310-1	350N
Gas Permeability	Methane Permeability	BS EN ISO 15105-1	<514ml/m <sup>2</sup> /day/atm
	Carbon Dioxide Permeability	BS EN ISO 15105-1	<514ml/m <sup>2</sup> /day/atm
	Radon Permeability	K124/02/95	4.3x10 <sup>-11</sup> m <sup>2</sup> /s
Compliance and Certification	CE Mark - EN13967:2012		
	NHBC Standards Compliant		
	BBA Certified - Certificate No. 20/5728		



# DAMP PROOFING

## Delta Water Based Epoxy Resin

Delta Water Based Epoxy Resin is suitable for all applications where concrete, or masonry requires waterproofing and protection. It is applied in the same manner as ordinary emulsion paint with the added benefit of application in damp conditions. Once dried Water Based Epoxy leaves a tough, non-toxic, waterproof, damp proof and easy to clean surface.

Supplied in a twin-pack. Mixing Delta Water Based Epoxy couldn't be easier – simply remove the ring which holds both tins together. Add Pack B (smaller tin) into Pack A (larger tin) stirring continuously. Stirring should be for a minimum 5 minutes from time when Part A and Part B are added together.

### Features

- As a membrane to prevent rising damp in floors or anti-lime treatment of new concrete
- As a general waterproofing and decorative finish for all brick, concrete, cement and masonry surfaces
- For damp surfaces where other paints cannot adhere
- As a tank lining for protection against mild chemicals
- All other applications where a waterproofing coating is required
- Non-Toxic, tough, and durable

### Fields of Application

- Basements and areas needing a damp proof membrane
- Water tanks and sewage treatment plants
- Abattoirs and fisheries
- Dairies, milking parlours, food factories, breweries
- Grain silos, bunds and water plants
- Chemical industry garages
- Plant rooms

### Specification

- NBS Specification J30 Liquid Applied damp proofing/Tanking
- 110 – Cold Applied

### Product details

DMS 485	2.5 ltr	White
DMS 486	2.5 ltr	Clear
DMS 487	2.5 ltr	Grey
DMS 488	2.5 ltr	Blue
DMS 144	5 ltr	White
DMS 148	5 ltr	Clear
DMS 149	5 ltr	Grey
DMS 150	5 ltr	Blue



### Technical data

DMS	485-140
Curing	Tough cure in 4 hours. Hard dry in 12 hours. Maximum cure in 8 days
Packaging	Two-Part product
Coverage	Coverage is approximately 7 m <sup>2</sup> per 1 litre. This may be reduced on rougher more porous substrates
Storage	Store in a cool, dry conditions. Store in original tinned packaging. Protect from frost.
Shelf life	A shelf life in excess of 12 months can be expected
Cleaning equipment	If using spray equipment, rinse thoroughly with cold water frequently to avoid build up of cured paint. Brushes and rollers should be washed in cold water and mild detergent

# DAMP PROOFING

## Delta LM 800

Delta LM 800 is an innovative, robust and flexible liquid membrane suitable for damp proofing, waterproofing and ground gas protection conforming to BS 8102:2022 and BS 8485:2015+A1:2019.

Delta LM 800 performs excellent under high compressive loads and offers maximum protection in just one application.

Delta LM 800 offers a simple and continuous prevention barrier against the ingress of methane, carbon dioxide and radon and moisture into buildings.

Delta LM 800 is an elastic, UV-resistant, single component system supplied in black. This non-hazardous product can be applied direct from its packaging using a roller, brush or airless spray.

### Features

- Waterproof and damp proof
- Multiple physical properties, including resistance to methane, carbon dioxide and radon
- Complies with BS 8102:2022 Protection of below ground structures against water ingress. Code of practice.
- Resistant to ground water in accordance with BS 8102:2022
- Ideal for complex detailing and difficult to reach areas
- Fully bonded system
- Continuous application - no sealing required at construction joints/laps
- Can be applied to damp surfaces or newly poured concrete
- Quick drying

### Fields of Application

- Delta LM 800 Liquid Membrane is suitable for damp proofing, gas proofing and waterproofing a variety of substrates including concrete, masonry and metal, above and below ground level including retaining walls, cast concrete, precast concrete and steelwork.
- Designed for use in applications where combined damp proofing and gas protection are required.
- Delta LM 800 can be applied by brush, roller or airless sprayer.
- Apply first/ priming layer at rate of 0.5kg/m<sup>2</sup> ensuring that coating is applied evenly over the surface. Allow first coat to fully dry. Drying times may vary due to ambient conditions. (Product will change colour from light grey to black when dry).
- Protect application from frost and rain until application is fully dried and cured.
- Application should only be made when air and surface temperature is 5°C and rising.
- Total application thickness should not exceed 4mm and should be at least 1mm.



### Technical data

Physical Properties	
Applied Thickness	>1.0mm
Form Supplied	Viscous Liquid
Pack Size	10kg
Colour	Grey/Black once cured
Physical Properties	
Methane Permeability	<12ml/m <sup>2</sup> /Day/ATM ISO EN 15105-1

### Specification

- BS 8485:2015+A1:2019 Code of practice for the design of protective measures for methane and carbon dioxide ground gases for new buildings
- BS 8102:2022 Type C Drained Protection
- NBS Specification J30 Liquid Applied Tanking/Damp Proofing

### Product details

DMS 035



# DAMP PROOFING

## Koster

### Koster Repair Mortar Plus

Fast setting, expanding repair mortar – Koster Repair Mortar Plus is a watertight, fast setting, slightly expanding repair mortar with excellent adhesion (even to old building material substrates). With the addition of Koster SB Bonding Emulsion, it can be used as a PCC (polymer-modified cement concrete) mortar. Repair Mortar Plus can be used for underfilling machine foundations as well as for filling blowholes, cracks, tie bolt holes & oversized joints

#### Features

- Watertight
- Fast Setting
- Slightly expanding
- Excellent adhesion
- Can be applied to all mineral substrates
- Suitable for watertight repairs and touch ups to substrates
- Positive and negative side waterproofing
- Can be used internally and externally on concrete, brickwork, blockwork or masonry
- Easy application
- Seamless application



### Koster NB 1 Grey

Koster NB 1 Grey Crystallizing mineral waterproofing slurry system for sealing against pressurized water (> 13 bar). Koster NB 1 is a mineral coated waterproofing slurry containing crystallising and capillary-plugging agents. It can be used for waterproofing against ground moisture and for non-pressurized and pressurized water. NB 1 Grey is characterized by its excellent resistance to pressure and abrasion as well as chemical and sulphate resistance.

#### Features

- Positive and negative side waterproofing against pressurized water
- Resistant against chlorides, sulphates and phosphates
- Certified for drinking water environments
- Penetrates the surface where crystallization leads to inseparable waterproofing-substrate bond – does not contain corrosion promoting ingredients
- No VOC emissions
- No emissions of environmentally harmful ingredients works also on masonry and on very porous substrates like shotcrete, aerated concrete and cinderblock
- Substrate does not have to be continually kept wet to cure
- Once first layer has cured, can be covered with subsequent layers



## DAMP PROOFING

# Koster

### Koster Façade

Koster Facade Cream is a market leading water-resistant hydrophobic cream for protecting structures and facades from water and driving rain. Koster Facade Creams exceedingly high resistance against alkalinity, is also competent for installation to fresh mineral substrates. Koster Facade Cream is water vapour absorbent, which secures buildings from rainwater and is a repellent to de-icing salts and frost.

#### Features

- Easy application (brush, rolling or spraying)
- High resistance to alkalinity
- Protects buildings from driving and normal rain water
- Water vapour permeable
- Resistant to frost and de-icing salts
- Solvent free
- Colourless after curing
- Liquid (Cream) applied
- Suitable for making absorbent mineral substrates water repellent
- Resistant to salts
- Environmentally friendly
- Creamy, stable consistency



### Koster KBE Liquid Film

Koster KBE Liquid Film is a highly elastic, solvent-free sealing compound with a rubber/bitumen basis. Suitable for foundation waterproofing and intermediate waterproofing on horizontal areas such as terraces, balconies, wet and moist rooms (under screeds) in above and below ground construction and garages. KBE Liquid Film is also suitable for waterproofing floor areas against rising damp.

#### Features

- Positive side waterproofing against pressurized water
- Waterproofing on horizontal areas
- Applied over plaster or concrete, flush jointed masonry or Koster NB 1 Grey
- Seamless application
- Suitable for new construction and repair on existing structures
- Suitable for waterproofing basements
- Suitable for waterproofing floor areas against rising damp
- Can be used undiluted in a thin layer as a primer
- Can be applied with a brush, roller, trowel, paint brush or suitable spray equipment
- Fresh coatings can be protected from rain by applying Koster BE Rainproof





# DAMP PROOFING

## Koster

### Koster Restoration Plaster White

Koster Restoration Plaster White is a salt, moisture and pressure resistant restoration plaster for the restoration of heavily moist and salt burdened substrates, due to its high porosity and hydrophobicity it allows for a damage free drying and desalination of masonry. Restoration Plaster White is suitable for multiple substrates include concrete, masonry consisting of brick, natural stone, porous concrete block, perforated brick, mixed masonry, etc.

#### Features

- Due to its high porosity and hydrophobicity, Koster Restoration Plaster White allows for damage free drying and de-salting of masonry even in the case of high salt contents
- Restoration Plaster White improves the insulative properties of the wall and therefore helps prevent the formation of condensation
- Suitable substrates include concrete, masonry consisting of brick, natural stone, porous concrete block, perforated brick, mixed masonry, etc.
- Restoration Plaster White is free of light fillers and therefore requires no further surface treatment prior to the application of breathable paints or wallpaper which is open to vapour diffusion



### Koster Restoration Plaster Grey

Koster Restoration Plaster Grey is a salt, moisture and pressure resistant restoration plaster for the restoration of heavily moist and salt burdened substrates. Restoration Plaster Grey is suitable for multiple substrates include concrete, masonry consisting of brick, natural stone, porous concrete block, perforated brick, mixed masonry, etc. Koster Restoration Plaster Grey can also be used as a water repellent exterior plaster.

#### Features

- Due to its high porosity and hydrophobicity, Koster Restoration Plaster Grey allows for damage free drying and de-salting of masonry even in the case of high salt contents
- Restoration Plaster Grey improves the insulative properties of the wall and therefore helps prevent the formation of condensation
- Suitable substrates include concrete, masonry consisting of brick, natural stone, porous concrete block, perforated brick, mixed masonry, etc.
- Restoration Plaster Grey is free of light fillers and therefore requires no further surface treatment prior to the application of breathable paints or wallpaper which is open to vapour diffusion



## DAMP PROOFING

# Koster

### Koster Fine Plaster

Koster Fine Plaster is hydrophobic, water, weather and frost resistant plaster. Finely textured thin layer plaster for smooth decorative surfaces on Restoration Plasters and mineral based substrates. It can be applied in layer thicknesses from 2 – 5 mm and is felt-floatable.

#### Features

- Can be finished with paint or wallpaper
- Fine Plaster is especially suitable as an area and fine plaster over mineral substrates, Restoration Plasters and base plasters
- Easy application
- Seamless application
- Fine Plaster can be used in interior and exterior applications in old and new construction for renovating facades, skirting and interior walls
- Suitable for new construction and repair on existing structures
- Suitable for crack repair with embedded Glass Fibre Mesh and subsequent fine plaster



### Koster Fine Plaster Key Course

Koster Restoration Plaster Key Coarse is a thin slurry which is used as a bonding bridge between a substrate and Restoration Plaster. Restoration Plaster Key Coarse is a fast, course plaster key with polymer additives for substrate preparation. Restoration Plaster Key Coarse can be applied on dry, moist, very moist and high salt burdened substrates.

#### Features

- Suited for all absorbent mineral surfaces.
- Suited as primer for restoration plasters
- Positive and negative side waterproofing against pressurized water
- Easy application
- Seamless application
- Suitable for new construction and repair on existing structures
- Can be applied on dry, moist, very moist and high salt burdened substrates



# DAMP PROOFING

## Koster

### Koster Mortar Tight

Koster Mortar Tight is a waterproofing liquid additive which prevents the transmission of water through renders, screeds, and/or sealing slurries. This versatile product improves the density of the mortar structure, making the mortar water repellent (hydrophobic), furthermore, Koster Mortar Tight promotes self-healing of microcracks through crystallization.

Koster Mortar Tight increases the impermeability of mortars and slurries against moisture, dampness, hydrostatic pressure and driving rain. Koster Mortar Tight, is free from chlorides and nitrates.

#### Features

- Wall Render and Screed applications
- Resists pressurized water (on negative side)
- Unlike standard dense render systems, it has the ability to seal micro cracks
- Easy to apply
- Suitable for above and below ground application
- Suitable for residential and commercial projects



### Koster Thermal Plaster

Koster Thermal Restoration Plaster is a pure mineral insulating plaster with good thermal insulation properties that is free from plastics. Ideal for the repair of masonry damaged by moisture and salt, especially after the installation of horizontal barriers.

Koster Thermal Restoration Plaster is suitable for all moisture and salt levels in masonry. Koster Thermal Restoration Plaster can be used to improve the insulation value of masonry and prevents mold growth.

#### Features

- Allows masonry to dry and desalinate without damage even at high salt levels
- Suitable for heavily moisture and salt-contaminated substrates
- Offers a reduction of condensation levels/improves the indoor climate
- High thermal efficiency, and is hydrophobic
- Salt encapsulating
- Lightweight
- Can be applied at a layer thickness up to 50mm



# DAMP PROOFING

## Koster

### Koster Crisin Cream

Koster Crisin Cream is a retroactive DPC (Damp Proof Course), for damp proofing against capillary rising moisture. It can be applied inside and/or outside a structure. This injection DPC cream is based on resin/silane which protects against capillary rising moisture/ rising damp (wicking moisture). Crisin Cream is resistant against any moisture/salt content.

#### Features

- Provides a permanent horizontal barrier against rising damp in masonry
- Easy application
- Seamless application
- Fast curing
- Applied in cases of high degrees of moisture penetration (95%+/-5% saturation)
- Applied in cases of high degrees of salt contamination
- Suitable for indoor and outdoor use
- Quickly resistant to rain
- Suitable for new construction and repair on existing structures



### Koster Crisin 76 concentrate

Koster Crisin 76 penetrates deeply into even the smallest capillaries and pores in building materials. Due to its very low density and surface tension lower than that of water, Crisin 76 Concentrate displaces the water in capillaries. Capillaries lined with Crisin 76 Concentrate are lined with resin and hydrophobic. The curing of the injected product is independent of the drying of the masonry.

#### Features

- Fast reaction, immediately effective
- Remains flexible
- Does not decay or decompose
- Acts neutrally
- Does not effloresce
- Does not affect steel reinforcement
- Resistant to all of the usual corrosives in masonry such as acids, alkalis, and salts
- Easy application
- Seamless application
- Suitable for new construction and repair on existing structures
- Suitable even in cases of high moisture contents until 95% ± 5%
- Suitable even in cases of high salt contents





# DAMP PROOFING

## Technical Drawings

### DDP-100-1- Delta MS 500 as DPM to Ground Floor Slab / Options

#### TYPICAL FLOOR FINISH OPTION

THIS OPTION APPLIES TO 3mm, 8mm, OR 20mm. STUD DESIGN

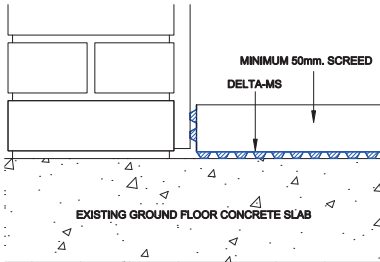

#### TYPICAL FLOOR FINISH OPTION

THIS OPTION APPLIES TO 3mm, 8mm, OR 20mm. STUD DESIGN

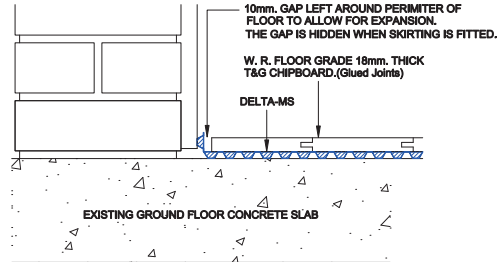

#### TYPICAL FLOOR FINISH OPTION

THIS OPTION APPLIES TO 3mm, 8mm, OR 20mm. STUD DESIGN

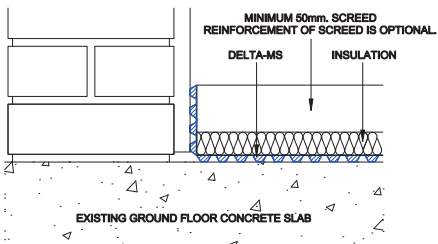

#### TYPICAL FLOOR FINISH OPTION

THIS OPTION APPLIES TO 3mm, 8mm, OR 20mm. STUD DESIGN

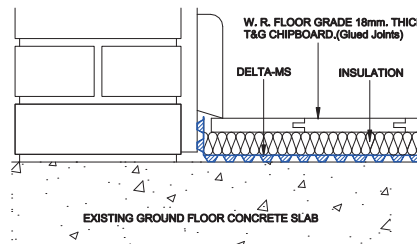

### DDP-102-1- Above Ground Damp Proof Membrane

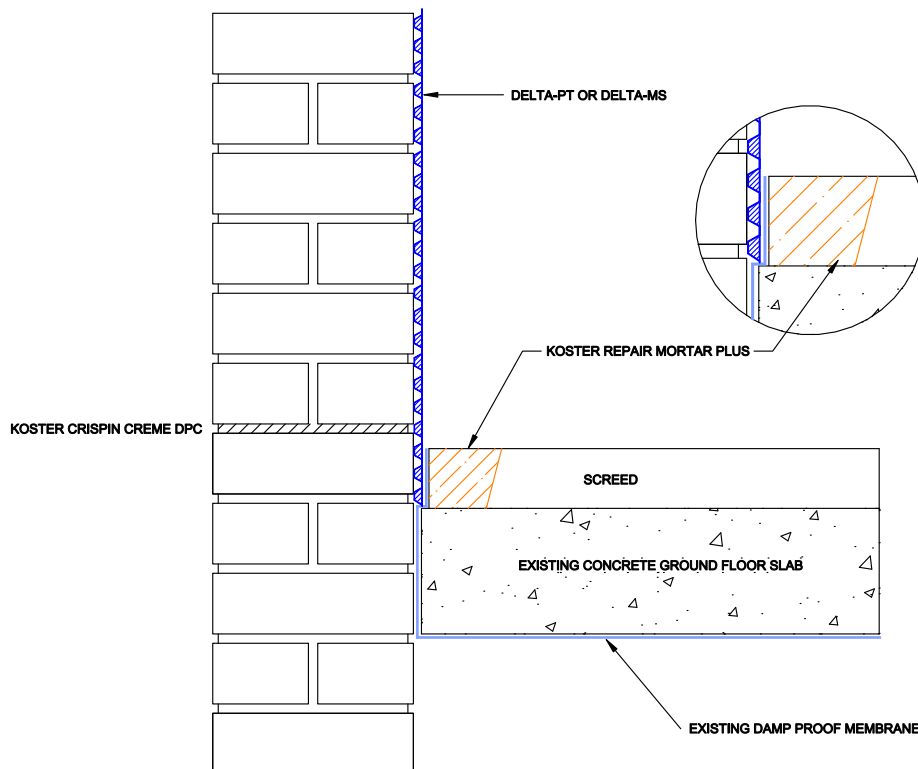

**DDP 106-1 Delta System 500 - Existing Solid Wall/Floor Detail**

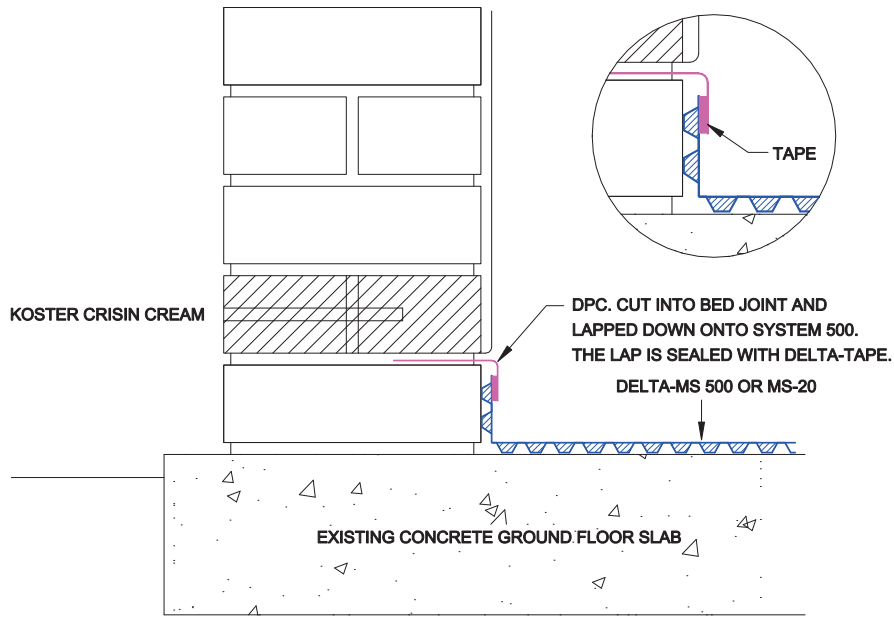

**DDP - 159-1 Delta PT Profile Ventilation Strip**

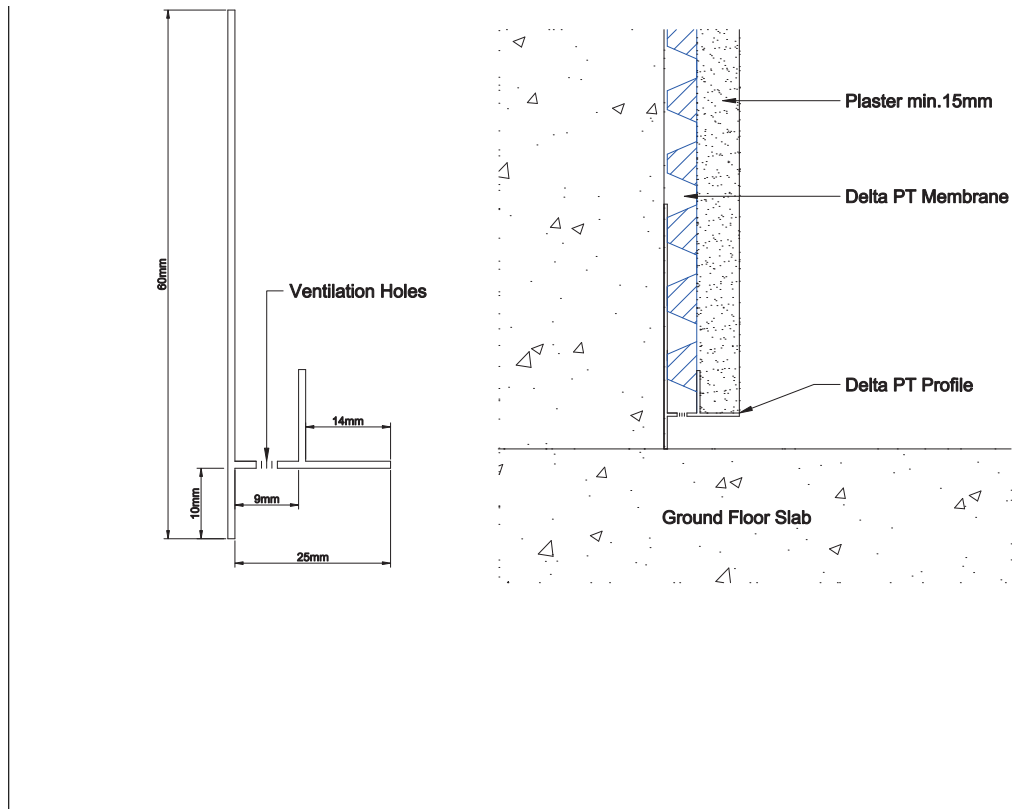

# DAMP PROOFING

## Technical Drawings

### DDP 234-1 Delta Water Based Epoxy Floor Detail

PARTY WALL / FLOOR DETAIL

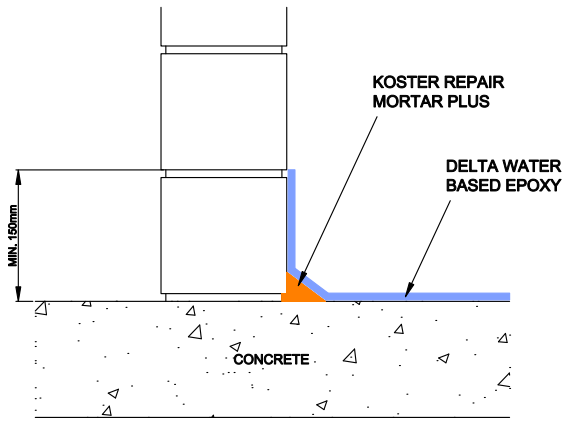

CONSTRUCTION JOINT / FLOOR DETAIL

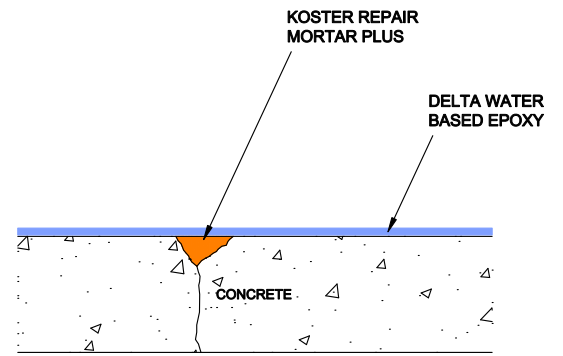

RAISED ACCESS FLOOR DETAIL

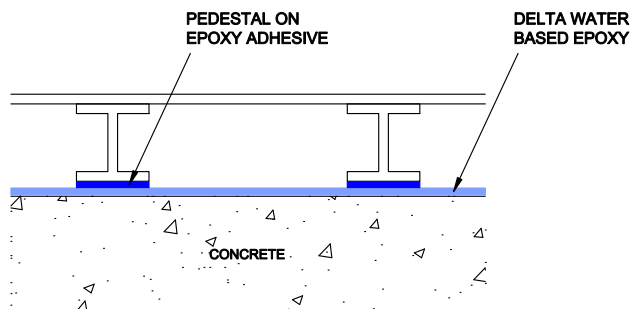

INTERNAL WALL / FLOOR DETAIL

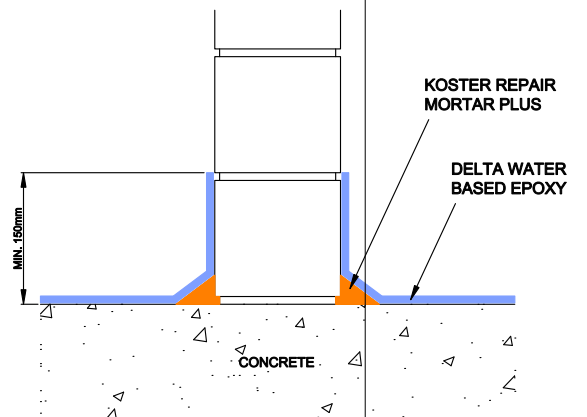

## DDP - 560-1 PT 3mm Wall Finishes

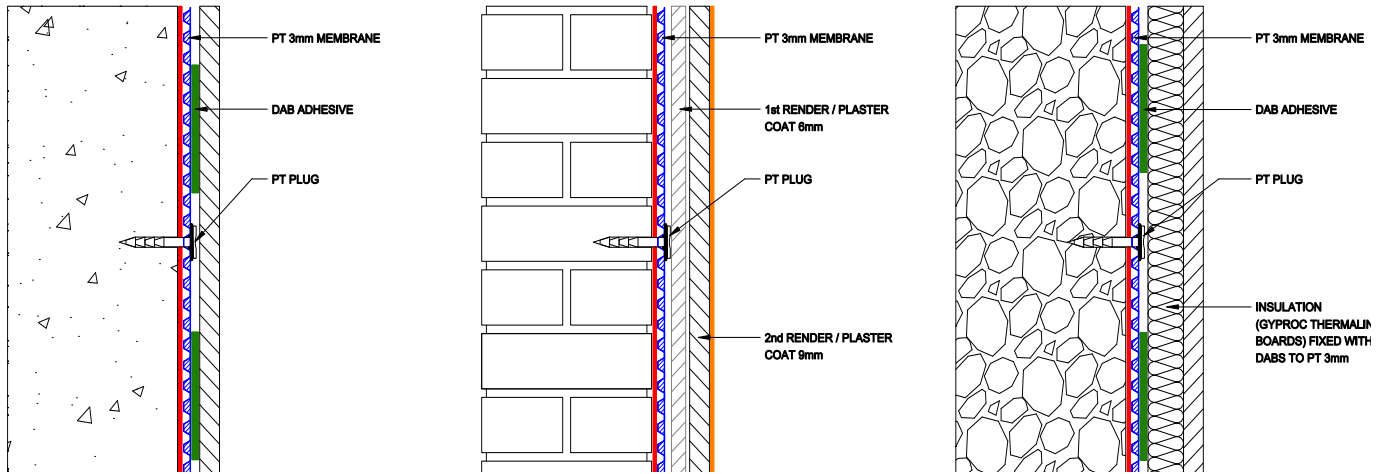

## DDP - 561-1 Damp Proofing Membranes

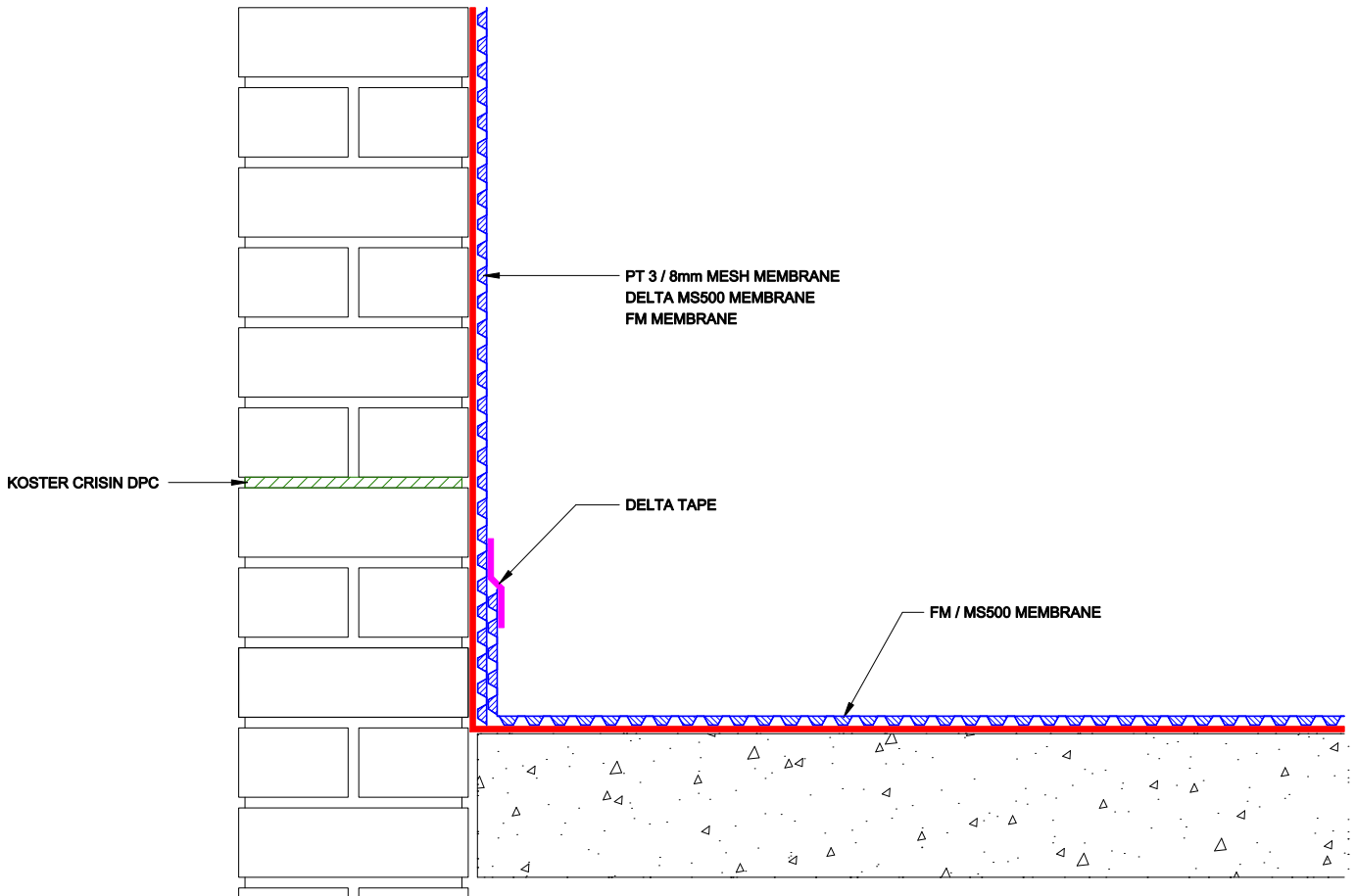



**HEAD OFFICE**

Delta House, Merlin Way, North Weald, Epping, Essex, CM16 6HR  
01992 523 523 | [info@deltamembranes.com](mailto:info@deltamembranes.com) | [www.deltamembranes.com](http://www.deltamembranes.com)