

LinearClad™ F Façade System

HunterDouglas® LinearClad™ are particularly suited to large surface areas and offer excellent design, functionality and comfort with an outstanding visual appeal.

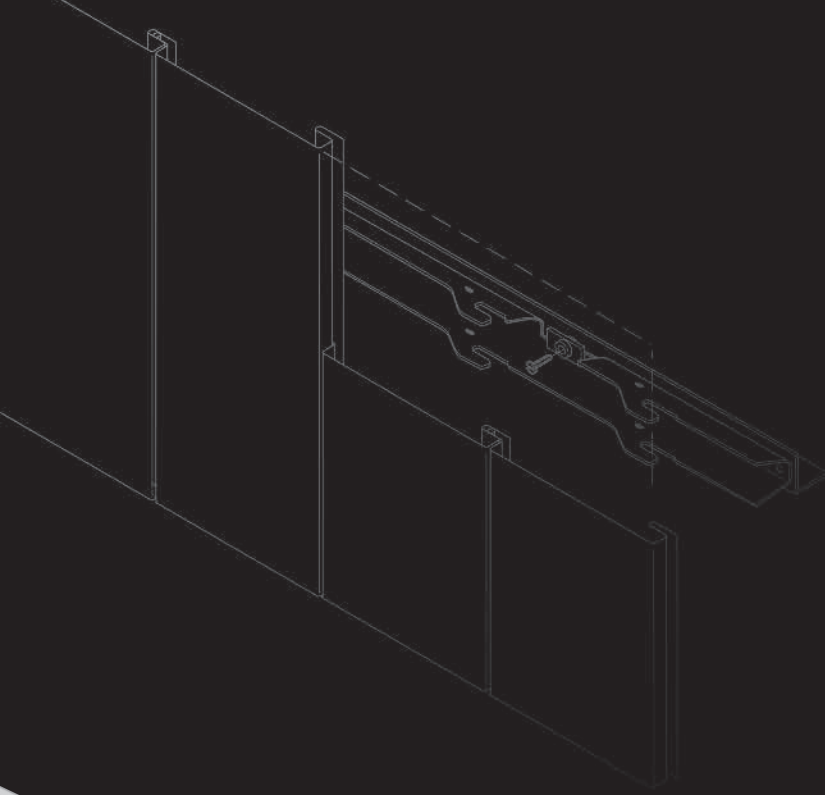

HunterDouglas 
Architectural



LinearClad™ F Façade System

Economical cladding with excellent performance

DESIGN FLEXIBILITY

Hunter Douglas LinearClad™ F within the Façade product range, gives architects the freedom to choose the right and economical cladding to meet aesthetic, performance and comfort criteria.

ECONOMICAL

Our LinearClad™ F Façade System is an economical cladding and soffit solution without compromising on technical performance. Single Skin façades create smooth, profiled surfaces that are ideal for new and refurbished projects. They are easy to install, lightweight and available in 2 widths (150 mm and 200 mm) and in a wide range of colours.

DURABILITY

The high quality components, used to manufacture the façades, deliver high performance and low maintenance: products built to last.

SYSTEM FEATURES

LinearClad™ F consist of 150 mm and 200 mm wide roll formed panels with a tight joint. The panels are made to measure and can be supplied in any length from 800 up to 6000 mm.

- Light crowned modules of 150 and 200 mm
- Roll formed tongue-in-groove system
- Perfect for façade projects
- Optimised system for medium wind load
- Large choice of colour possibilities.



FORM & DESIGN

Buildings are defined by form and design. Often they are the product of an architect's inspirational vision. At Hunter Douglas our mission is to help designers realise that vision, by providing them with a palette of colours, materials and surface finishes that will inspire their creativity.

CONTENT	Page
LinearClad™ F	2
Maximum spans LinearClad™ 150F	3
Maximum spans LinearClad™ 200F	4
Hunter Douglas Architectural	5

APPLICATION

- Façades and exterior ceiling
- Sloping and curved façades
- Decoration of exterior walls, ceilings and balconies
- Cladding of tunnels
- For new build or renovation projects.

Designed to work for you



Production by
Hunter Douglas
Ceiling Center



HunterDouglas

LinearClad™ F

PANELS

The Hunter Douglas 150F/200F Façade System consists of 150 mm and 200 mm wide roll formed panels (1), which can simply be slid into the prongs of a 150F or a 200F stringer (2). The stove enamelled aluminium panels are recyclable, lightweight and strong. The panels are made to measure and can be supplied in any length from 800 up to 6000 mm (other lengths are available on request). Panels can be joined by using the panel splice (3).

The stringer (2) is black, made of 0.95 mm thick (150F) or 1.2 mm thick (200F) stove enamelled aluminium and is provided with prongs to accommodate the panels. Stringers have a standard length of 5000 mm.

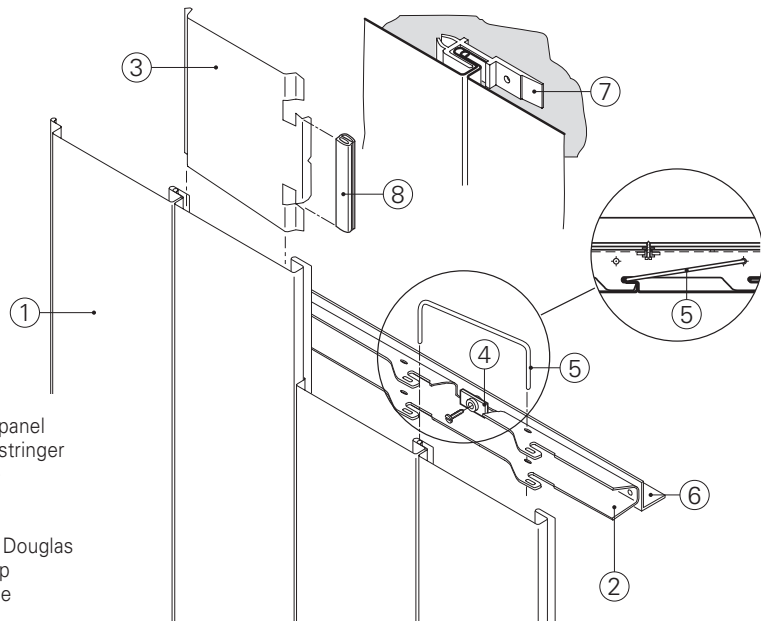

- 1 = 150F/200F panel
- 2 = 150F/200F stringer
- 3 = panel splice
- 4 = washer set
- 5 = U-bracket*
- 6 = non-Hunter Douglas
- 7 = screw-clamp
- 8 = sealing piece

* Only used in case of extreme windloads

Note: 150F/200F panels can be installed horizontally, vertically or diagonally depending on desired directional emphasis.

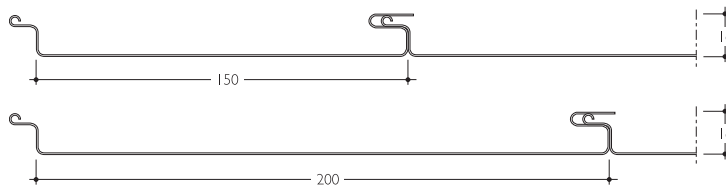

PRACTICAL APPLICATIONS

- The neat closed joints present a smooth uninterrupted appearance.
- The façades have a concealed fixing system.
- Panel length made to measure from 800 up to 6000 mm, allowing for swift installation and reducing the need for joining the panels to a minimum.
- Panels can be additionally secured to the stringer by using U-brackets (5), providing a very rigid system, able to withstand the most severe conditions of water and wind (over 2000 N/m²).
- Panels are made from a corrosion resistant aluminium alloy.
- The Luxacote® coating combined with aluminium of the highest category for corrosion resistance guarantees:
 - Colour and gloss stability;
 - High scratch resistance;
 - High corrosion resistance.
- For installations requiring combinations of 150F and 200F panels a screw clamp (7) is available.
- Curved façades can be achieved by using screw clamps (7).
- Façades are based on a ventilating principle providing optimum control of building physics.

STANDARD CONSTRUCTION DETAILS

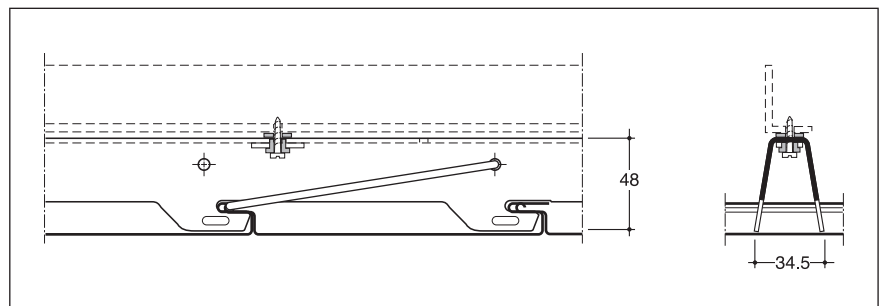

DIMENSIONS & WEIGHTS

Panel	Width	Module	Min. Length	Max. Length	Weight panels & stringer/m ² *
150F	150	150	800	6000	2.8 kg
200F	200	200	800	6000	3.1 kg

* Based on panels installed on 3 or more stringers with a windload (pressure) of 1500 N/m².

MATERIAL REQUIREMENTS PER M²

	Unit	150F system	200F system
Panels	lm	6.67	5.00
Stringers	lm	1.54	1.92
Screws	pcs	4.16	4.80
Washer sets	pcs	4.16	4.80

The required number of components depends on individual project requirements. Figures are based on a façade installed on 3 or more stringers and submitted to a windload (pressure) of 1500 N/m².

LinearClad™ 150F

MAXIMUM SPANS

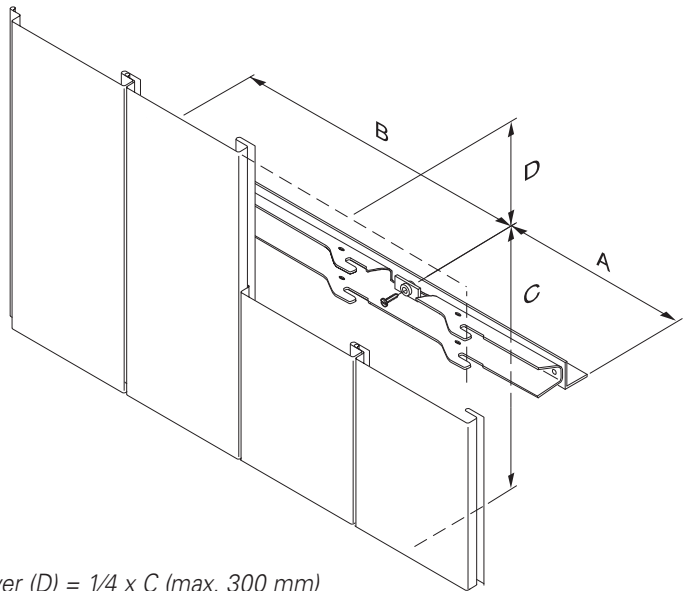

Panel cantilever (D) = 1/4 x C (max. 300 mm)
Stringer cantilever (A) = 1/4 x B

- Panel span (C)

The panel spans, in relation to the wind load (pressure or suction), can be calculated from the graph on the right. At 1500 N/m² the maximum panel span for 150F is 0.65 m on 3 or more stringers (windsuction).

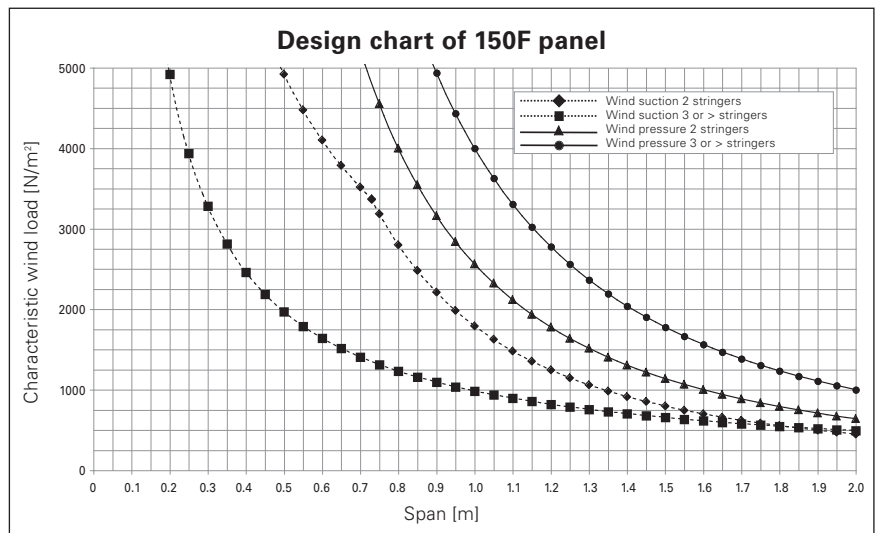

- Stringer span (B)

Before establishing the fixing distance of the stringers, the load per lineal meter stringer is to be determined by applying the formula in the following table.

Panels installed on:	Calculation of 'load per lineal meter stringer'
2 stringers	$0.5 \times q \times l$
3 stringers	$1.25 \times q \times l$
4 or more stringers	$1.15 \times q \times l$

q = windload in N/m² (uniformly distributed loads)

l = panelspan (c) in m

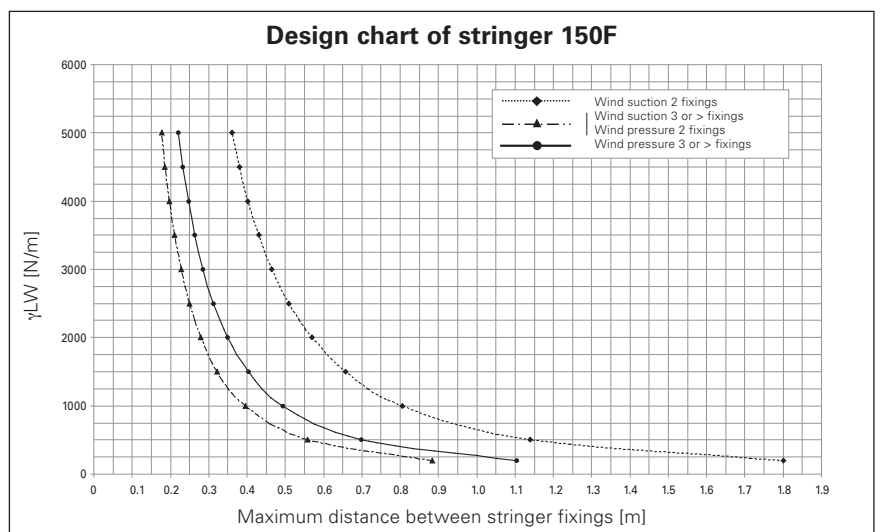

Following the example:

$$Q = 1,15 \times 1500 \times 0,65 = 1121 \text{ N/m.}$$

Giving a fixing distance of 0,37 m.

LinearClad™ 200F

MAXIMUM SPANS

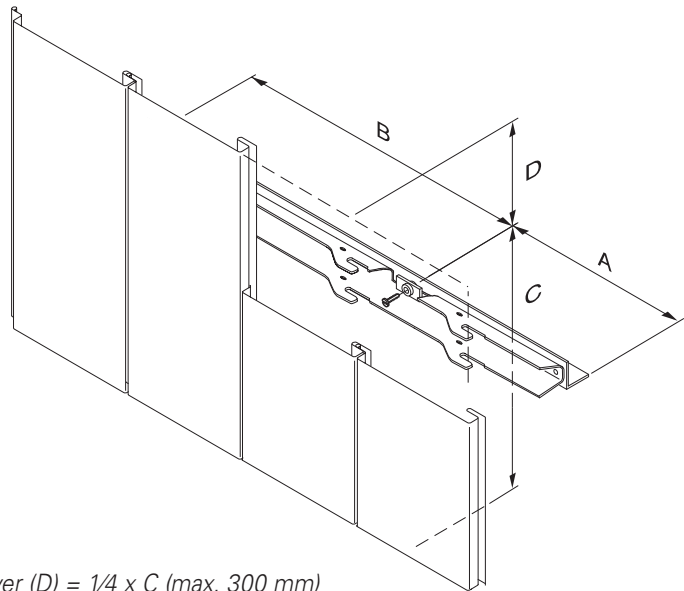

Panel cantilever (D) = 1/4 x C (max. 300 mm)
Stringer cantilever (A) = 1/4 x B

- Panel span (C)

The panel spans, in relation to the wind load (pressure or suction), can be calculated from the graph on the right. At 1500 N/m² the maximum panel span for 200F is 0.52 m on 3 or more stringers (windsuction).

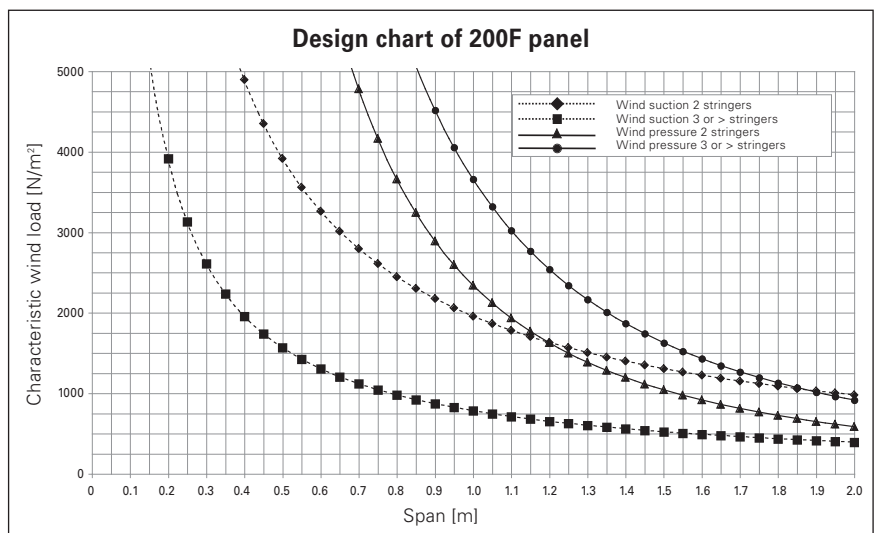

- Stringer span (B)

Before establishing the fixing distance of the stringers, the load per lineal meter stringer is to be determined by applying the formula in the following table.

Panels installed on:	Calculation of 'load per lineal meter stringer'
2 stringers	$0.5 \times q \times l$
3 stringers	$1.25 \times q \times l$
4 or more stringers	$1.15 \times q \times l$

q = windload in N/m² (uniformly distributed loads)

l = panelspan (c) in m

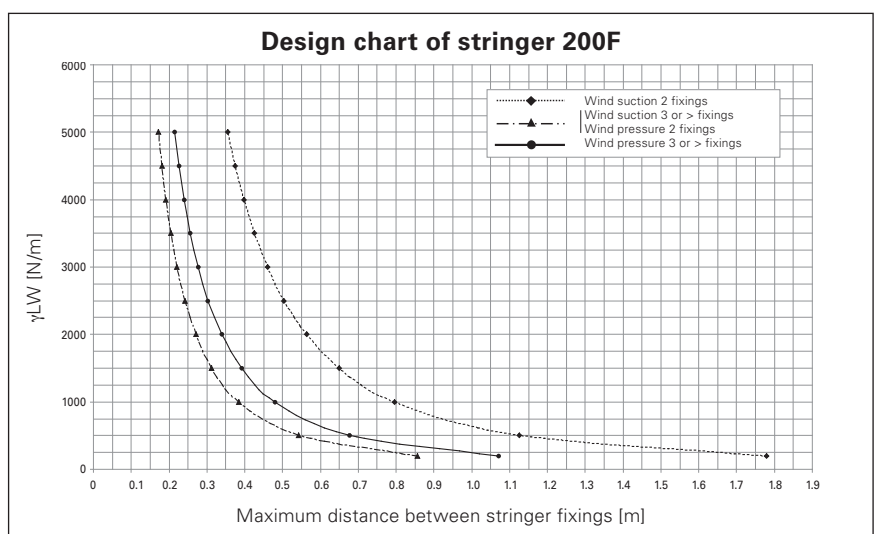

Following the example:

$$Q = 1,15 \times 1500 \times 0,52 = 897 \text{ N/m.}$$

Giving a fixing distance of 0,4 m.

HUNTER DOUGLAS ARCHITECTURAL

In the last 60 years, we have been fortunate enough to help turn countless innovative ideas into products for innovative buildings. With major operation centres in Europe, North America, Latin America, Asia and Australia we contribute to thousands of high-profile projects including shopping centres, airports, government offices, hospitals, universities and offices.



▲ SUN LOUVRES



▲ CEILINGS



▲ CEILINGS



▲ FAÇADES

ARCHITECTURAL SERVICES

We support our business partners with a wide range of technical consulting and support services for architects, developers, and installers. We assist architects and developers with recommendations regarding materials, shapes and dimensions, colours and finishes.

We also help creating design proposals, visualisations, and installation drawings. Our services to installers range from providing detailed installation drawings and instructions to training installers and advising on the building site.

Designed to work for you



Hunter Douglas adopts the cradle to cradle (C2C) product philosophy to the design of products that fit the circular paradigm. They are designed for longevity, using materially healthy technical nutrients that can be reused at end of life as a high-quality source for something new.

Cradle to Cradle Certified™ is a certification mark licensed by the Cradle to Cradle Products Innovation Institute.



Hunter Douglas products and solutions are designed to improve indoor environmental quality and conserve energy, supporting built environments that are comfortable, healthy, productive, and sustainable.



All aluminium products are 100% recyclable at the end of their lifecycle.



Learn More

- Contact our Sales office
- www.hunterdouglasarchitectural.eu

© Registered trademark - a HunterDouglas® product Pats. & Pats. Pend. - Technical data subject to change without notice. © Copyright Hunter Douglas 2020. No rights can be derived from copy, text pertaining to illustrations or samples. Subject to changes in materials, parts, compositions, designs, versions, colours etc., even without notice.

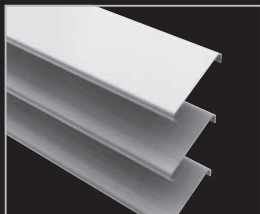

84R

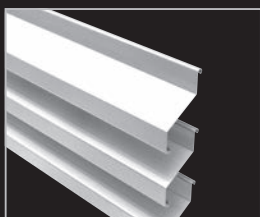

70S

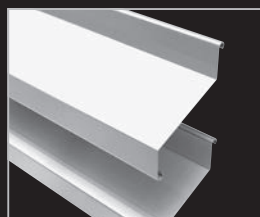

132S

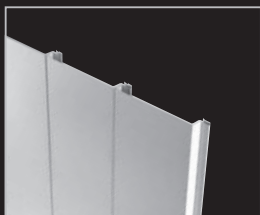

150F/200F

Belgium
Bulgaria
Croatia / Slovenia
Czech Republic
Denmark
France
Germany
Greece
Hungary
Italy
The Netherlands
Norway
Poland
Portugal
Romania
Russia
Serbia
Slovakia
Spain
Sweden
Switzerland
Turkey
United Kingdom
Africa
Middle East

Asia
Australia
Latin America
North America

Hunter Douglas Architectural

Piekstraat 2
P.O. Box 5072 - 3008 AB Rotterdam
The Netherlands
Tel. +31 (0)10 - 486 99 11
Fax +31 (0)10 - 484 79 10
www.hunterdouglasarchitectural.eu