

# Quality precast concrete manufacturers

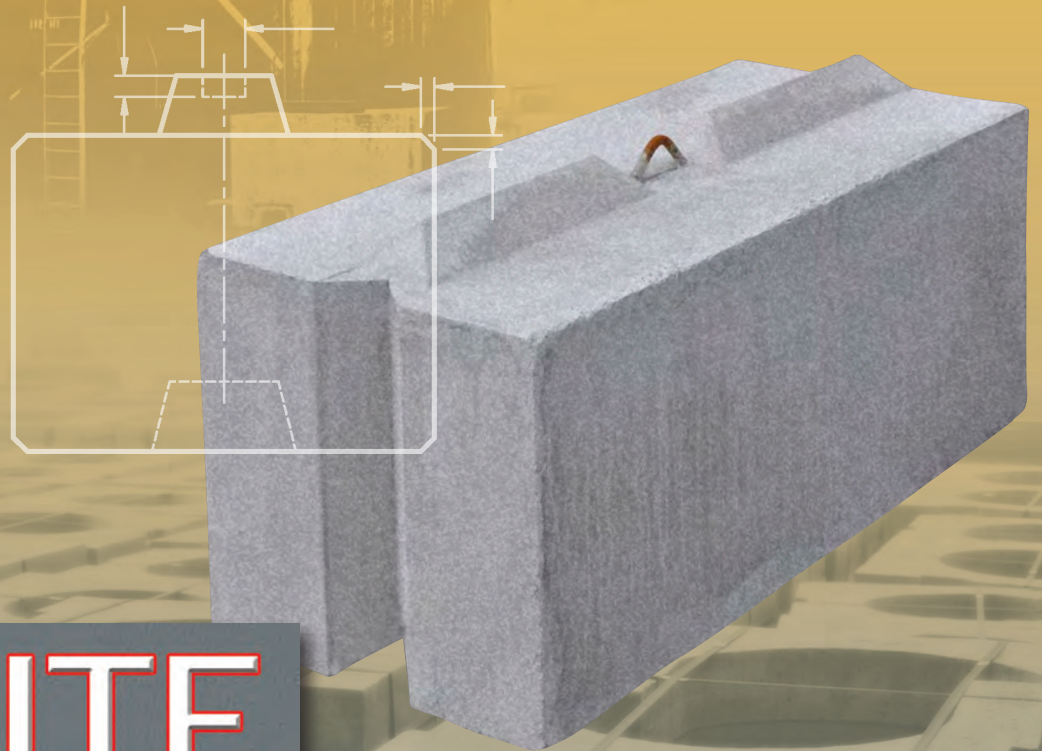

**ELITE**  
PRECAST CONCRETE

# Elite Precast Concrete

Elite Precast Concrete Ltd are a dynamic and innovative precast concrete company based in Telford, Shropshire. Founded by Richard Doody and Alan Johnson in January 2008, the business has gone from strength to strength by combining the highest levels of customer service with always being the lowest cost option.

Drawing on over 40 years of combined experience, Elite Precast Concrete are leading the way in manufacturing low-cost precast concrete products for numerous applications. From two-part seating rings and cable protection tiles through kentledge, troughs and lids to a variety of retaining wall blocks, Elite have gained a strong reputation for great value products which can be supplied anywhere in the UK. And now Elite's latest innovation is proving to be a real hit with waste, recycling and aggregate supply companies alike - the revolutionary Interlocking Block System.

Our ethos of producing the right products at the right price has enabled the company to expand rapidly. By continually re-investing into the business and driving down the cost base we are able to offer a nationwide service at 'local' price levels.

The ever-growing range of 'standard' wet-cast and semi-dry products are complimented by a 'tailor-made' service which involves working in collaboration with clients to design and manufacture the lowest cost precast concrete solution to any problem or opportunity that might arise.

Our product range is constantly expanding as we source new markets and innovative new products. Find the product you require opposite or check out the custom manufacturing pages here or on the website for tailored solutions.



[www.eliteprecast.co.uk](http://www.eliteprecast.co.uk)  
01952 588 885



## contents

nationwide delivery .....	3
manufacture & design.....	4
customer solutions .....	5
quality testing .....	6
finance .....	8
product range contents.....	9
conversion guide .....	10
products.....	11
terms & conditions.....	45



# nationwide delivery and beyond

## **We can supply our products anywhere in the UK, and further afield if required!**

Through our network of approved delivery partners we have access to an extensive transport fleet of specialist vehicles enabling us to provide fast, safe and efficient delivery of our products to your site.

We regularly keep over £300K worth of standard products in stock allowing, in most cases, for delivery times of between 24 and 48 hours from receipt of your order.

All our operatives are trained to the highest standards to make sure all products are loaded efficiently and correctly ensuring they reach our customers safely and in premium condition.

We can, of course, also accommodate customers who wish to arrange their own transport solution and are happy to supply suggestions and advice should it be required.

We can also deliver further afield if required. Our products can be found as far away as Australia and also at these far-flung destinations:

- Saudi Arabia
- Ascension Islands
- Qatar
- Gibraltar
- United Arab Emirates
- USA
- Norway
- Russia
- Falkland Islands
- Libya
- Jordan
- India



# designed & manufactured

Elite Precast Concrete is one of the leading manufacturers of low-cost precast concrete products in the UK.

Our in-house technical support and design team are always on hand to offer advice, provide estimates and help with project planning. We work together with our customers to ensure the most cost-effective solution can be achieved.

All our units are made to the highest standards at our two extensive modern manufacturing plants in Telford, Shropshire which cover fifty thousand square feet of production area and two and a half acres of stocking space. Rigorously applied procedures and the latest production techniques ensure consistency and efficiency, enabling us to provide high quality products at the most economic prices.

“...the simple and cost-effective solution provided by Elite’s blocks has meant that we can recycle a material that would otherwise have been disposed of in a landfill site. The blocks were quick to install and we can move them easily should we need to.”

Ian Chattington from Power Plane Ltd



[www.eliteprecast.co.uk](http://www.eliteprecast.co.uk)  
01952 588 885

# customer solutions

Elite Precast Concrete prides itself on its strong reputation for excellent customer service coupled with a flexibility and desire to find solutions to the most challenging of customer requests.

Our customer service and technical departments are renowned for their ability to modify and adapt our existing 'off the shelf' products to suit the most specific and exacting of requirements. This approach provides the customer not only with a considerable cost saving, from that of a totally bespoke product, but also a production and turn-around time that can be greatly reduced.

However, if this is not achievable, we have all the facilities necessary to produce completely custom-designed products to individual specifications.

By getting involved at the earliest stages of a project we can provide a mutually beneficial partnering solution saving our customers both time and money.

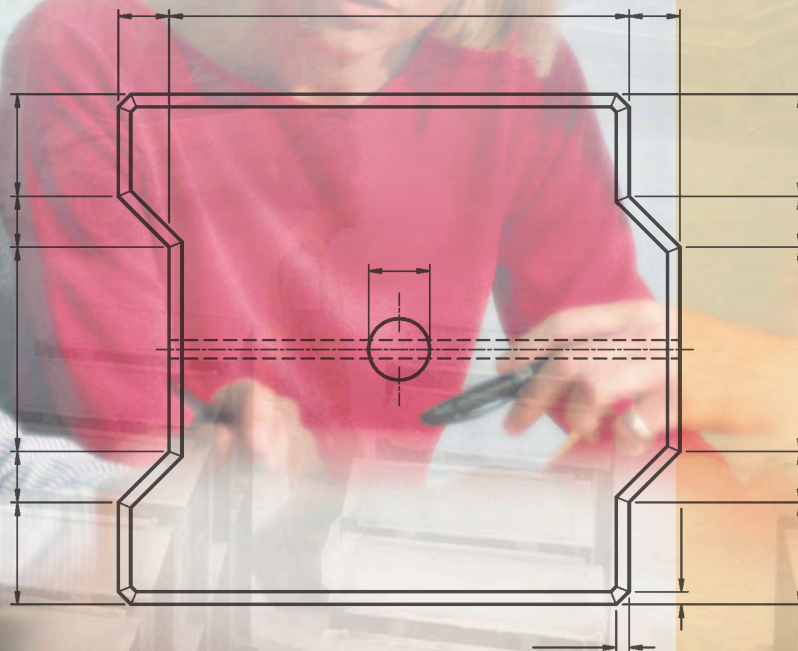
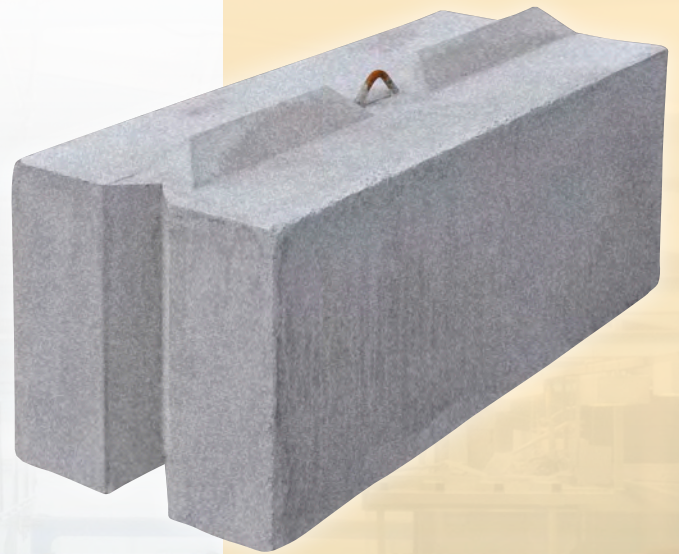

# testing for quality

The quality and consistency of our products is something we take very seriously. We operate within an approved BS EN 1917 quality system. We are one of the few manufacturers of precast concrete products in the country that can boast of having their own, purpose built, testing facility. We regularly perform a number of tests on both finished products and the materials used to manufacture these products.

## Making the grade - aggregate sieve analysis

A sieve analysis, or gradation test, is a procedure used to assess the particle size distribution within aggregates. An aggregate with an acceptable particle size distribution will depend on the particular product that the aggregate is to be used for and the end use that the product is required to perform.

The gradation test is performed on a sample of aggregate and involves a nested column of sieves with wire mesh cloth. A representative weighed sample of aggregate is poured into the top sieve which has the largest screen openings. Each lower sieve in the column has smaller openings than the one above. At the base is a round pan, called the receiver.

The column is then placed in a mechanical shaker and shaken, for a specific amount of time. After the shaking is complete the material on each sieve is weighed. The weight of the sample of each sieve is then divided by the total weight to give a percentage retained on each sieve.

The size of the average particle on each sieve is then analysed to get a cut-off point or specific size range, the results of which are then recorded. The grade and quality of the aggregate is then determined.



“ The installation went according to plan and the bunkers are working very well... Thanks for your excellent service! ”

Chris May, Sapa Profiles UK Ltd



## Performance under pressure **compression testing**

The Compression Test is a procedure to determine the characteristic strength of the concrete to establish that it is fit for purpose. Although it is a relatively simple test it is extremely important and helps us monitor and maintain the quality and integrity of our products.

Samples are taken from the concrete as it is poured into the product mould and, depending on the product being poured, cast in to a number of either 100mm or 150mm standard cube moulds. The samples are then left to cure under normal conditions. Once the samples have properly set they are removed from the moulds and catalogued with identification and batch numbers.

Cube samples are then placed in to the concrete compression apparatus and crushed to destruction. The test results indicate the maximum compressive strength of the concrete and results are recorded and filed. All the concrete used in Elite products is high strength 50N/mm<sup>2</sup>.

## Proving the product **cured stock testing**

We take regular cores from our products to check concrete strengths and aggregate distribution.

Daily tests are taken for aggregate moisture content, concrete hardness and reinforcement placement to ensure sufficient concrete cover to steel.

There are also several bespoke compression testing rigs to ensure product performance under specified usage conditions.

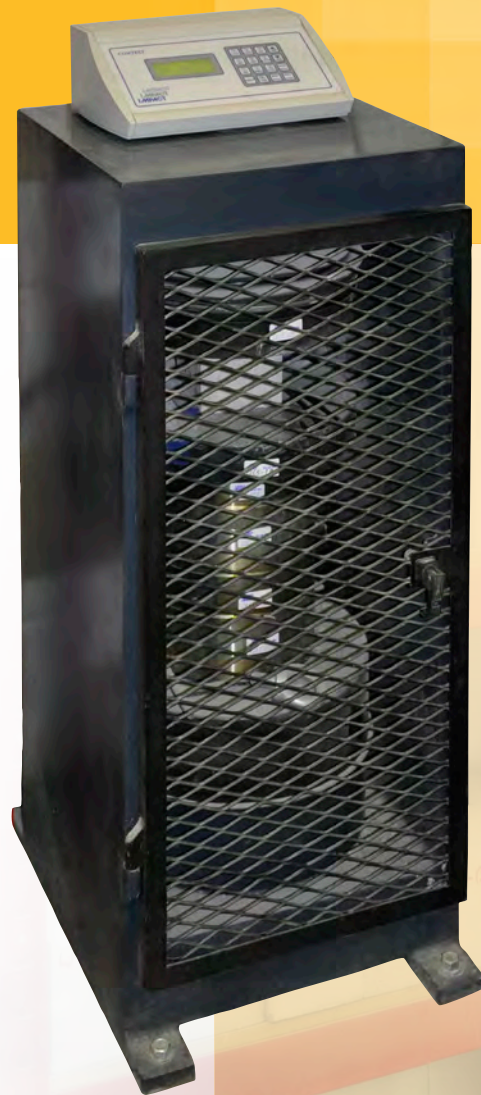

## Our unique finance packages

Elite have teamed up with Kata Crushing & Recycling Finance, a financial specialist for the recycling sector, to put together a dedicated deal that will enable clients to buy our V and Lego interlocking blocks using competitively priced finance.

This bespoke package enables our customers to spread the cost of buying precast concrete blocks over a range of timescales, easing their cash-flow and giving them the opportunity to fund larger scale initiatives.

The difficulties that many businesses experience raising finance have been well publicised, with funding the infrastructure element of a new project or business being the most problematic. However, with the support of Kata Crushing & Recycling Finance, Elite has been able to put together a carefully tailored range of options at very competitive rates.

Kata are delighted to work together with us on such a forward-thinking initiative. From experience, they know how frustrating it can be for firms trying to secure competitive funding for expansion and growth plans. This is a fantastic way for businesses to access the funding they need, and we are sure it will have a hugely positive impact on the industry.





# Elite product range

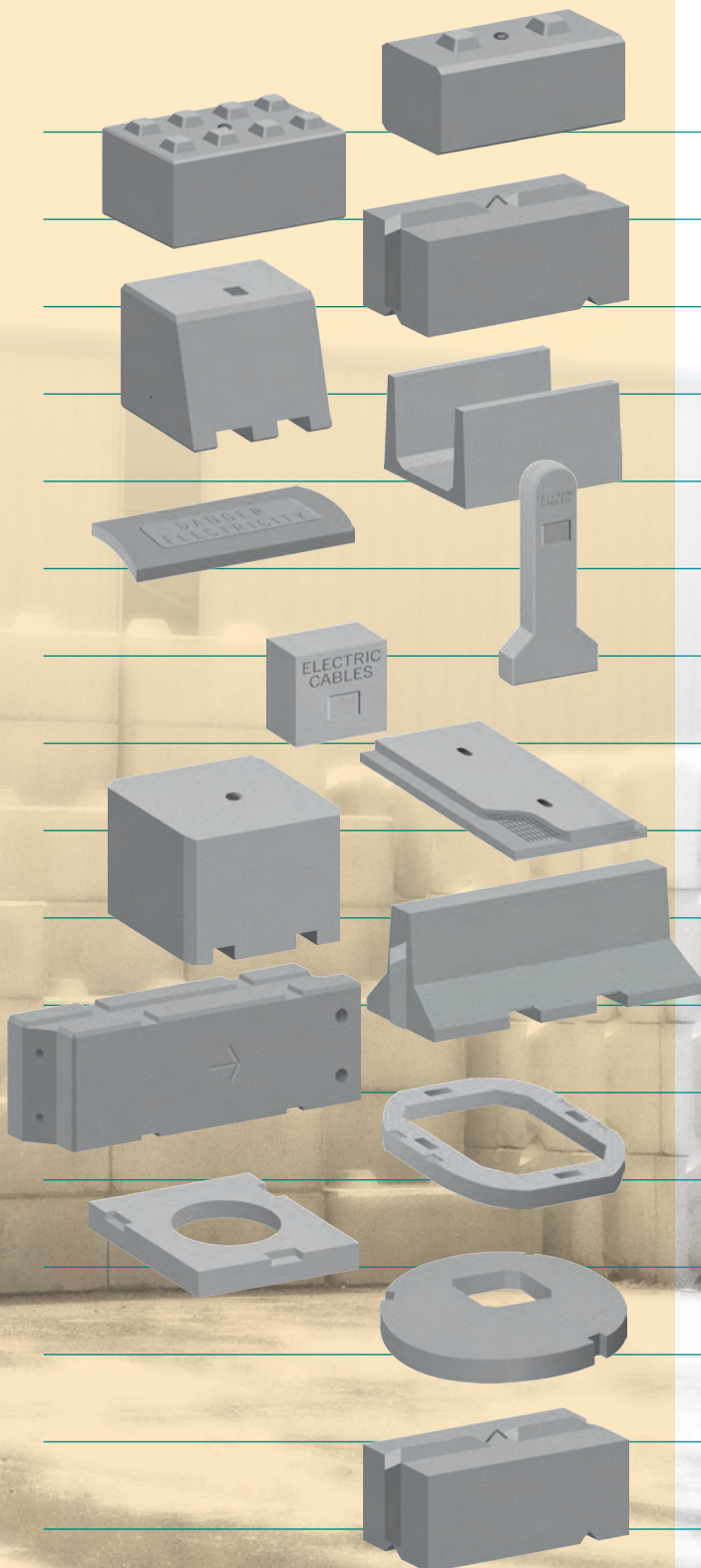

- 11 Duo™ Interlocking Concrete Blocks
- 13 Legato™ Interlocking Concrete Blocks
- 15 Vee™ Interlocking Concrete Blocks
- 17 Kentledge Blocks
- 19 Channels... Ducts... Troughs
- 21 Cable Protection Covers
- 23 Indicator Posts
- 25 Marker Blocks
- 27 Utility Protection Slabs
- 29 Security Blocks
- 31 Jersey Barriers
- 33 Temporary Vertical Concrete Barriers
- 35 Seating Rings / Adjusting Units
- 37 Gully Covers / Raisers
- 39 Manhole Cover Slabs
- 41 Dam Spillway Blocks
- 43 Counterweight Blocks
- 45 Sea Anchor Blocks

# conversion guide

## Length

One inch	= 25.4 millimetres
One foot	= 30.48 centimetres
One yard	= 0.9144 metres
One mile	= 1.609 kilometres
One millimetre	= 0.039 inches
One centimetre	= 0.0328 feet
One metre	= 1.094 yards
One kilometre	= 0.621 miles

## Area

One square inch	= 6.54 square centimetres
One square yard	= 0.8361 square metres
One square mile	= 2.589 square kilometres
One acre	= 4047 square metres
One square centimetre	= 0.155 square inches
One square metre	= 1.196 square yards
One square kilometre	= 0.386 square miles
One hectare	= 2.471 acres

## Weight

One ounce	= 28.349 grammes
One pound	= 0.4536 kilogrammes
One stone	= 6.35 kilogrammes
One cwt	= 50.8 kilogrammes
One ton	= 1.016 metric tonnes
One gramme	= 0.035 ounces
One kilogramme	= 2.2 pounds
One kilogramme	= 0.157 stones
One kilogramme	= 0.0197 cwts
One kilogramme	= 1.02 decanewton
One metric tonne	= 0.984 tons
One Newton	= 10.2 kilogrammes

## Volume

One cubic inch	= 16.38 cubic centimetres
One cubic foot	= 28.316 cubic decimetres
One pint	= 0.568 litres
One imperial gallon	= 4.546 litres
One cubic centimetre	= 0.061 cubic inches
One cubic decimetre	= 0.035 cubic feet
One litre	= 1.76 pints
One litre	= 0.22 imperial gallons

## Temperature

Centigrade/Celsius	= $(F-32) \times 0.55$
Fahrenheit	= $(C \times 1.8) + 32$

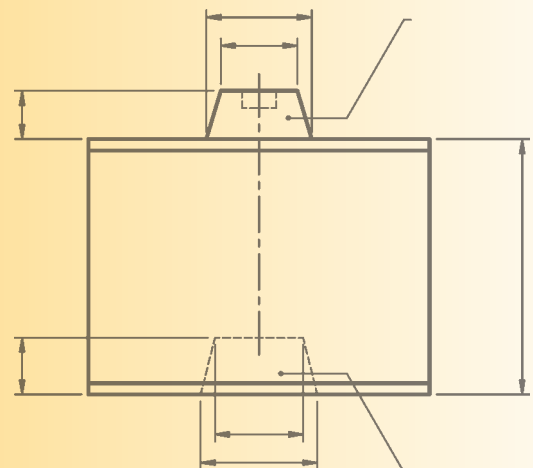
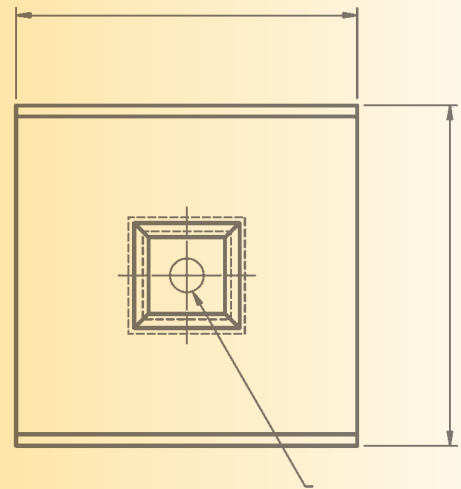

# Duo™ Interlocking Concrete Blocks



Class A1 fire resistant in accordance with clause 4.3.4.4 of EN 13369.

Elite are the UK's only manufacturer of Duo™ interlocking concrete 'lego' blocks - used throughout the UK in a wide variety of applications.

The clever design (which incorporates a cast-in lifting pin flush with the concrete surface) allows the blocks to be easily dry laid onto any firm surface, creating bay dimensions to suit almost any site. They are easily relocated or reconfigured as your business needs dictate.

The blocks are also excellent in many varied applications and provide a more simple, robust and cost-effective solution than conventional L or A-shaped thin-walled panels.

See overleaf for the full range and specifications.

Applications include...

- Bay walls**
- Silage clamps**
- Earth retention**
- Traffic calming**
- Security/property protection**
- Waste and recycling material segregation**
- Scrap and steel recycling**
- Security barriers**



For more information on Elite quality concrete products phone 01952 588 885 or browse [www.eliteprecast.co.uk](http://www.eliteprecast.co.uk)

# Duo™ Interlocking Concrete Blocks

## Duo™ interlocking block range

Our Duo™ blocks are the UK's fastest selling interlocking block solution. They come in three sizes - one, two and three connector - the standard block is a **BL2 1200mm x 600mm x 450mm** (highlighted in the table opposite) and weighs 750 kgs.

Speed of construction is a key feature - two men can expect to install 228 blocks per day which is over 123m<sup>2</sup>. The blocks interlock with each other using 'lego' type connectors and are dry-laid making them a reusable semi-permanent option. Capping pieces are also available to give a great looking finish.

A standard articulated lorry carries 38 of the 1200mm blocks although we are happy to deliver any number including single blocks.

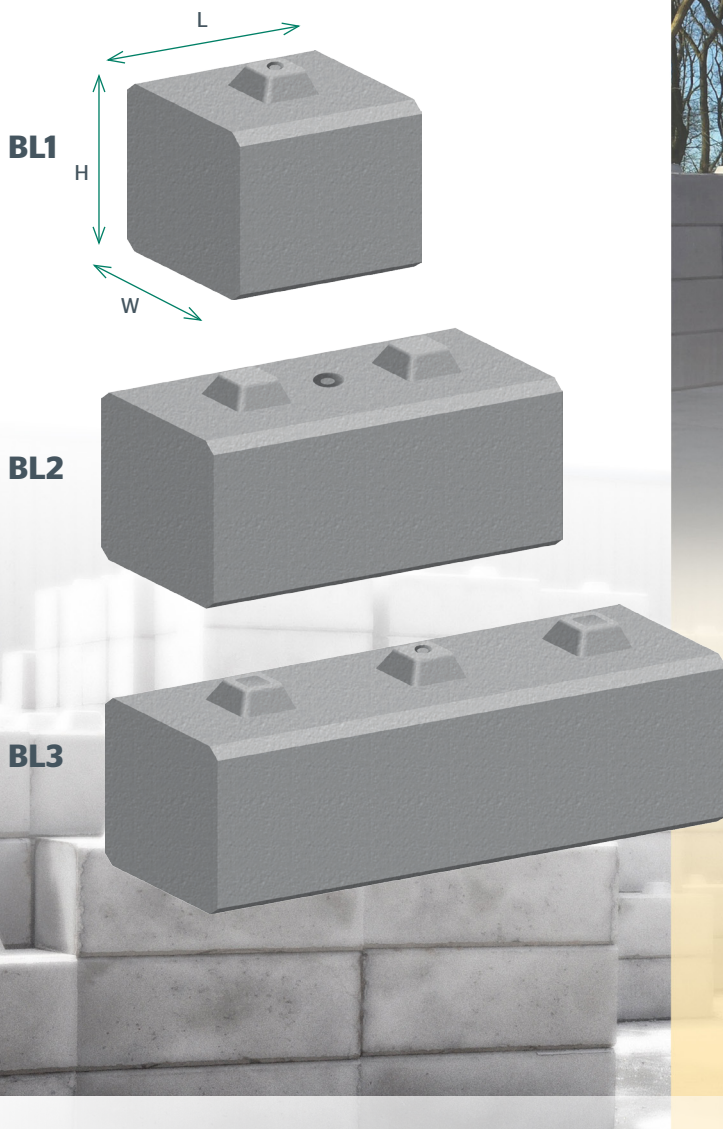

Duo™ Block	L x W x H mm	Weight	Code
BL1 (half)	600 × 600 × 450	375kg	BL-600
BL1 (F)	600 × 600 × 450	375kg	BLF-600
<b>BL2</b>	<b>1200 × 600 × 450</b>	<b>750kg</b>	<b>BL-1200</b>
BL2 (F)	1200 × 600 × 450	750kg	BLF-1200
BL3	1800 × 600 × 450	1125kg	BL-1800

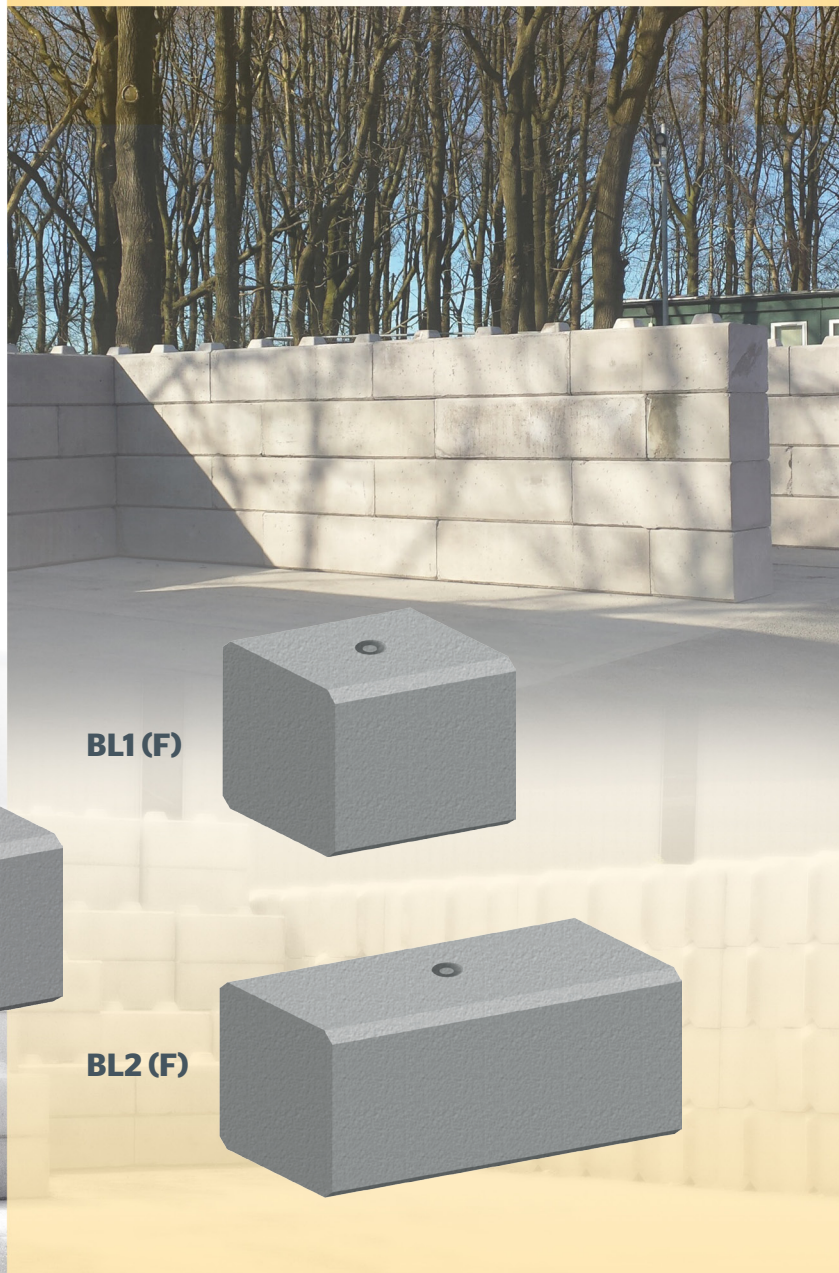

Elite Precast Concrete Limited  
 Halesfield 9, Telford, Shropshire TF7 4QW  
 Tel: 01952 588885 Fax: 01952 582011  
[www.eliteprecast.co.uk](http://www.eliteprecast.co.uk)

# Legato™ Interlocking Concrete Blocks



Class A1 fire resistant in accordance with clause 4.3.4.4 of EN 13369.

Elite are proud to present the ultimate interlocking block - Legato™, the name coming from the Italian for 'tied together'.

Elite are the only company in Europe to manufacture interlocking blocks using high strength (50N/mm<sup>2</sup>) concrete. This allows our Legato blocks to exhibit extreme levels of durability, combined with the flexibility of having their own cast-in lifting pin. As each standard block will build 1.28m<sup>2</sup> of wall, they provide an incredibly quick solution in a wide variety of applications.

These include...

**Support walls for roof structures**

**Bay walls**

**Push Walls**

**Silage clamps**

**Grain storage**

**Earth retention**

**Etc etc...**

In addition, because the blocks do not contain anything other than high quality, locally sourced aggregates and Portland Cement, you can be assured that your investment will last a lifetime.

See reverse for the full range and specifications.

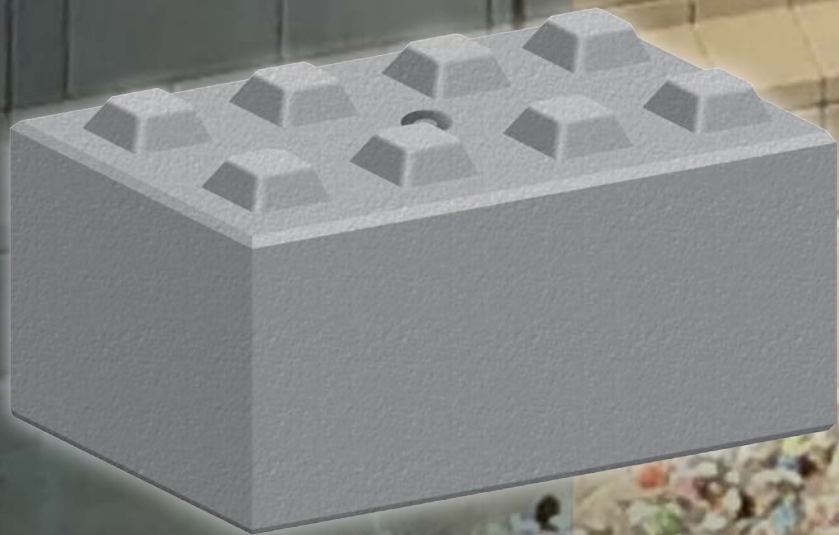

For more information on Elite quality concrete products phone 01952 588 885 or browse [www.eliteprecast.co.uk](http://www.eliteprecast.co.uk)

# Legato™ Interlocking Concrete Blocks

## Legato™ interlocking block range

Our Legato™ blocks come in various sizes - including flat top versions - the standard block is an **LG8 1600mm x 800mm x 800mm** (highlighted in the table opposite) and weighs in at 2400 kgs.

As each Legato™ block has its own lifting pin cast into it - you can easily change the way in which they are configured without the need for specialist lifting equipment or grabs.

Durability, strength and availability are the key features of these blocks and a next-day nationwide service means that you are never more than 24 hours away from taking delivery.

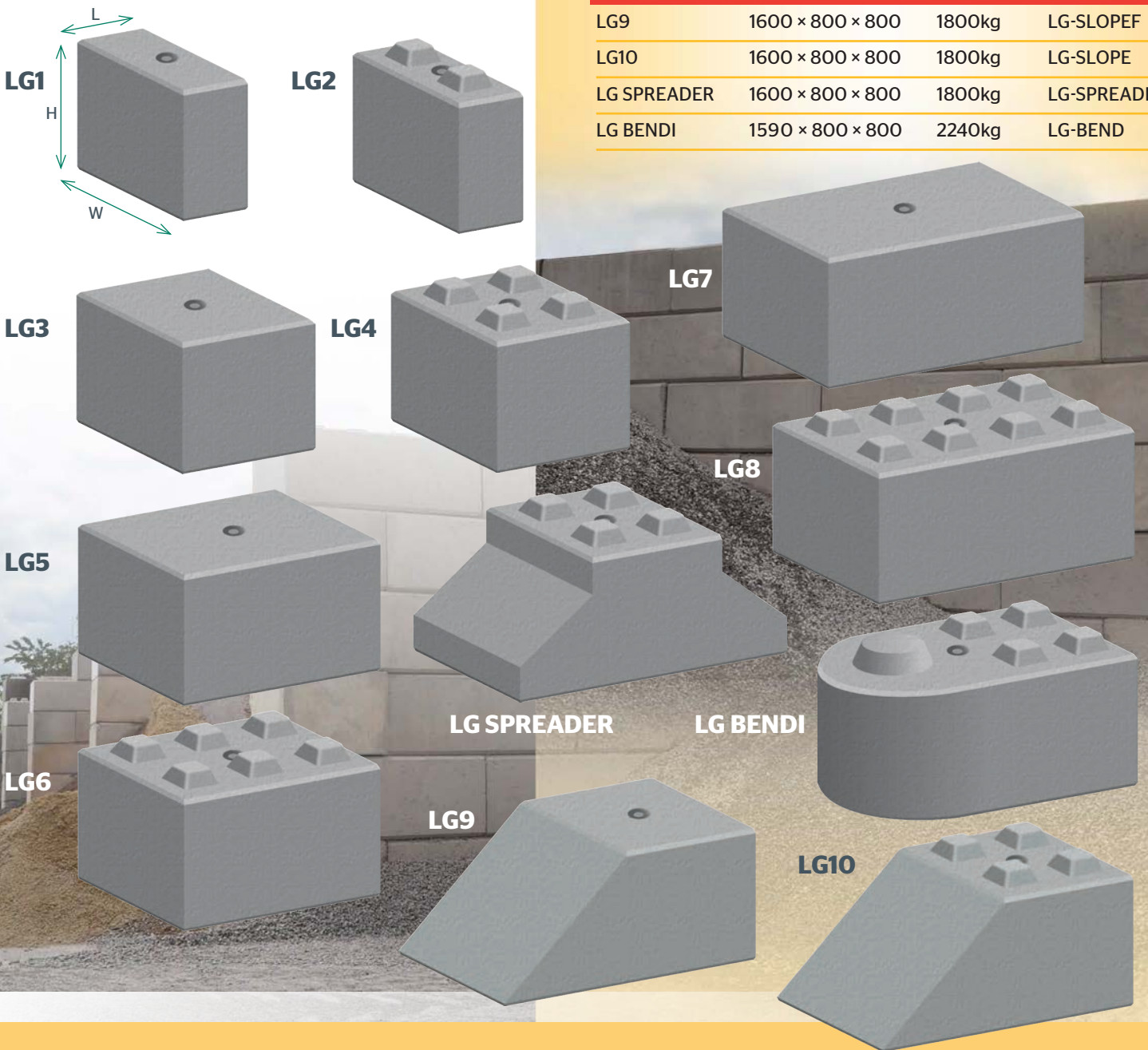

Legato™ Block	L x W x H mm	Weight	Code
LG1	400 x 800 x 800	540kg	LG-400F
LG2	400 x 800 x 800	600kg	LG-400
LG3	800 x 800 x 800	1080kg	LG-800F
LG4	800 x 800 x 800	1200kg	LG-800
LG5	1200 x 800 x 800	1620kg	LG-1200F
LG6	1200 x 800 x 800	1800kg	LG-1200
LG7	1600 x 800 x 800	2160kg	LG-1600F
<b>LG8</b>	<b>1600 x 800 x 800</b>	<b>2400kg</b>	<b>LG-1600</b>
LG9	1600 x 800 x 800	1800kg	LG-SLOPEF
LG10	1600 x 800 x 800	1800kg	LG-SLOPE
LG SPREADER	1600 x 800 x 800	1800kg	LG-SPREADER
LG BENDI	1590 x 800 x 800	2240kg	LG-BEND



Elite Precast Concrete Limited  
 Halesfield 9, Telford, Shropshire TF7 4QW  
 Tel: 01952 588885 Fax: 01952 582011  
[www.eliteprecast.co.uk](http://www.eliteprecast.co.uk)



# Vee™ Interlocking Concrete Blocks



Class A1 fire resistant in accordance with clause 4.3.4.4 of EN 13369.

Elite are the only manufacturer of a block which locks together both horizontally and vertically, the Vee™ Interlocking Concrete Block.

Originally designed to provide radiation shielding the Vee™ Interlocking block is an incredibly versatile product that will excel in the most demanding of applications. The blocks interlock with each other using a unique 'V' system along the base, sides and top giving incredible strength and stability.

No special foundations are required, just firm and level ground or a concrete pad.

The standard block is a **B1 1830mm x 610mm x 610mm** (highlighted in the table overleaf) and weighs in at 1600kgs. See reverse for the full range and specifications.

Applications include...

- Flood barriers**
- Sea defence**
- Radiation shielding**
- Grain storage**
- Soil/aggregate bay walls**
- Waste and recycling bays**
- Silage clamps**
- Earth retention**
- Security barriers**
- Traffic calming**



For more information on Elite quality concrete products phone 01952 588 885 or browse [www.eliteprecast.co.uk](http://www.eliteprecast.co.uk)

# Vee™ Interlocking Concrete Blocks

## Vee™ block types

All blocks measure 610mm square in cross section, but vary in length. B1 blocks are the standard type of block and are identified by having a V-shaped groove (female) on the bottom and one end of the block, and V-shaped projections (male) on the top and opposite end of the block. The direction of build is the direction in which the male projections should be pointing when assembling the wall.

B2 blocks are identical to B1 blocks with the exception that the male projection on the end of the block has been removed leaving a flat surface. The blocks are used to butt up to blocks which are at 90 degrees to the direction of build. They are also used at the end of walls to produce a smooth finish to the wall.

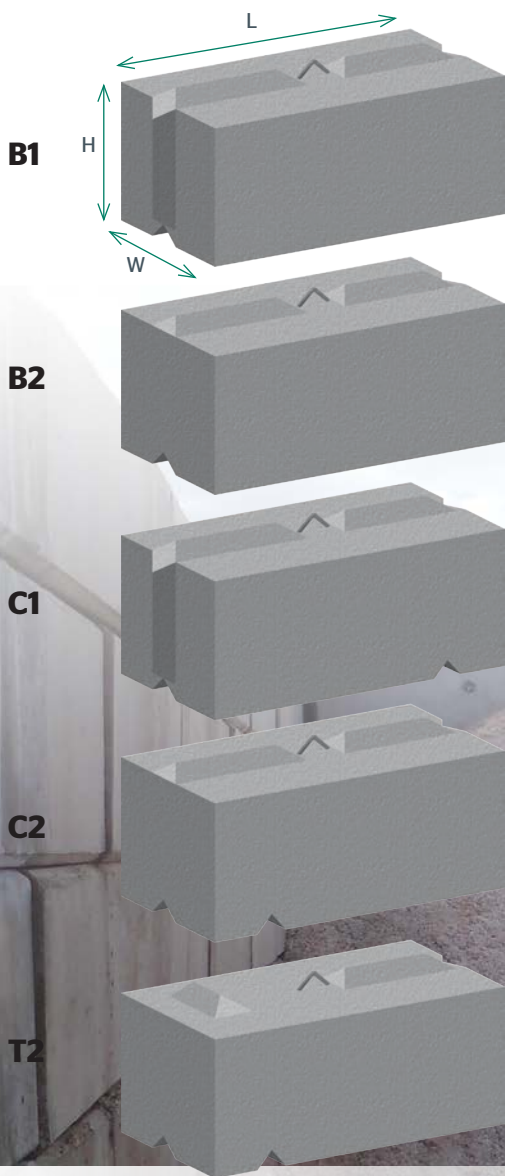

Vee™ Block	L x W x H mm	Weight	Code
B1	610 × 610 × 610	533kg	B1-610
	915 × 610 × 610	800kg	B1-915
	1220 × 610 × 610	1067kg	B1-1220
	1525 × 610 × 610	1333kg	B1-1525
	<b>1830 × 610 × 610</b>	<b>1600kg</b>	<b>B1-1830</b>
B2	610 × 610 × 610	533kg	B2-610
	915 × 610 × 610	800kg	B2-915
	1220 × 610 × 610	1067kg	B2-1220
	1525 × 610 × 610	1333kg	B2-1525
	1830 × 610 × 610	1600kg	B2-1830
C1 corner	1525 × 610 × 610	1333kg	C1-1525
C2 corner	1525 × 610 × 610	1333kg	C2-1525
T2	1525 × 610 × 610	1333kg	T2-1525
FB coping	610 × 610 × 610	533kg	FB-610
	915 × 610 × 610	800kg	FB-915
	1220 × 610 × 610	1067kg	FB-1220
	1525 × 610 × 610	1333kg	FB-1525
	1830 × 610 × 610	1600kg	FB-1830
HB coping	610 × 610 × 305	266kg	HB-610
	915 × 610 × 305	400kg	HB-915
	1220 × 610 × 305	533kg	HB-1220
	1525 × 610 × 305	666kg	HB-1525
	1830 × 610 × 305	800kg	HB-1830



C1 and C2 blocks (combination blocks) interlock courses at corners. As well as having the usual groove in the bottom of the block, combis have transverse grooves running across the width of the block. This is designed to lock the blocks in the course below. C1 blocks, (as with B1 blocks), have the male V projection on the end of the block. C2 blocks have a flat male end as with B2 blocks.

T2 blocks are specifically designed for the formation of intermediate bay walls. These blocks have a flat male face.

There are also a series of flat top coping blocks, these being standard 610 depths (FB blocks), or 305 depths (HB blocks).



## Kentledge blocks

Precast concrete kentledge blocks are used to act as ballast or counterweights for fencing, hoarding or scaffolding. They can also be attached to wire ropes which are fixed to the structure to provide greater stability.

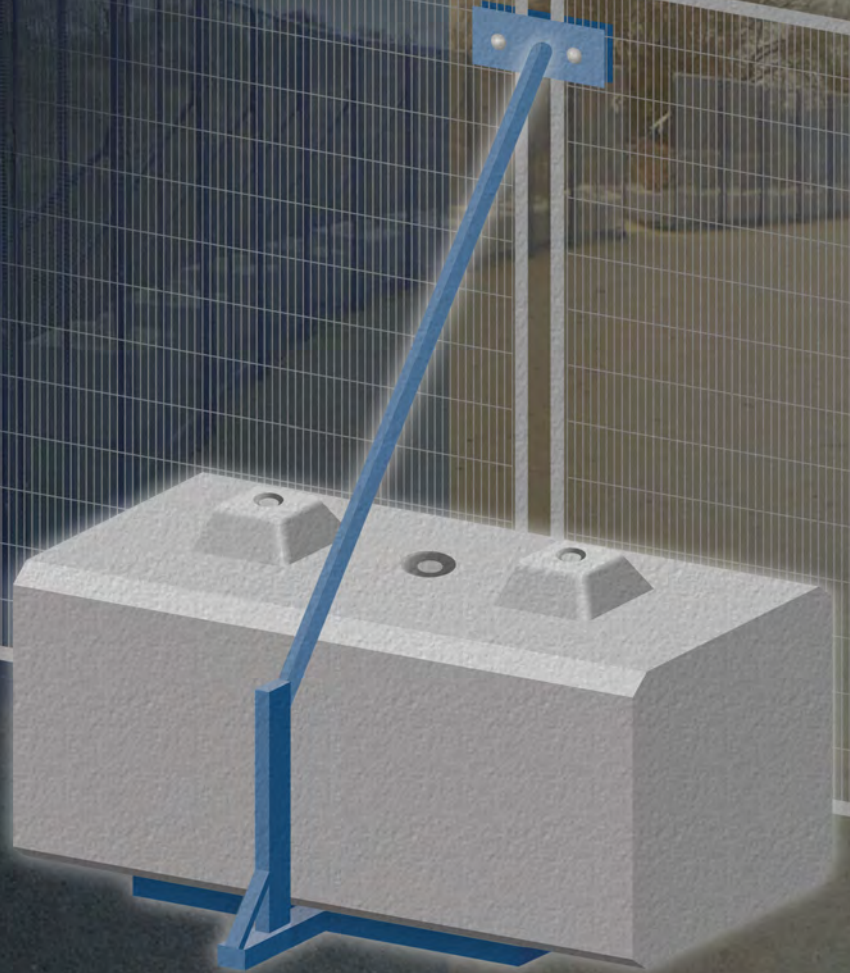

*Supplier of precast concrete kentledge blocks to the London 2012 Games (Olympic venues)*

For more information on Elite quality concrete products phone 01952 588 885 or browse [www.eliteprecast.co.uk](http://www.eliteprecast.co.uk)

# Kentledge blocks

## Block types

Elite offer a choice of products which can be used as kentledge/ballast blocks. The blocks shown and highlighted in **red** opposite are our most popular. Should you require different sizes then please refer to the rest of the table for size and style options.

### Duo interlocking block

750kg

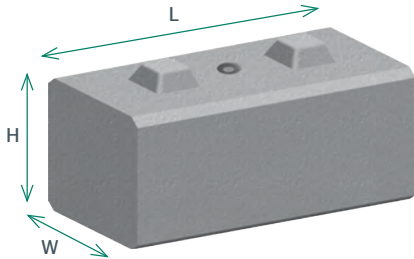

### Legato interlocking block

1200kg

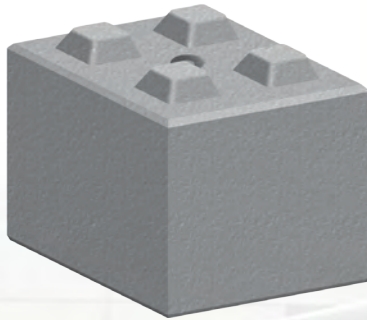

### Vee interlocking blocks

1600kg

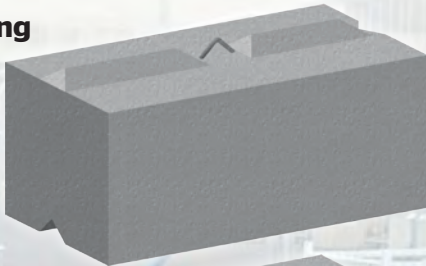

1333kg

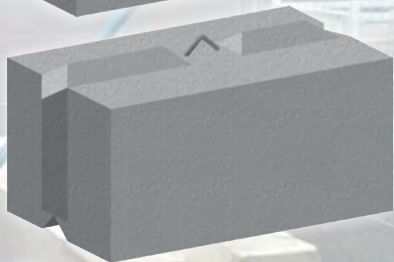

1067kg

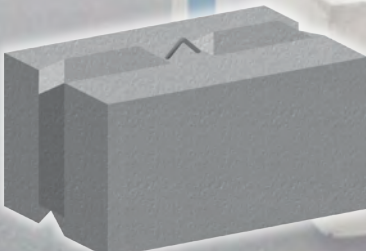

533kg

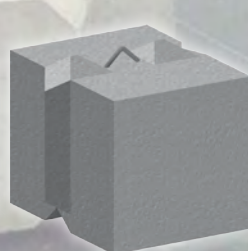

Weight	Length	Width	Height	Type	Code
<b>1000kg</b>	<b>1000mm</b>	<b>750mm</b>	<b>750mm</b>	<b>Marquee</b>	<b>KM1000</b>
<b>500kg</b>	<b>1000mm</b>	<b>550mm</b>	<b>400mm</b>	<b>Marquee</b>	<b>KM500</b>
<b>1200kg</b>	<b>800mm</b>	<b>800mm</b>	<b>800mm</b>	<b>Legato</b>	<b>KLG1200</b>
<b>750kg</b>	<b>1200mm</b>	<b>600mm</b>	<b>450mm</b>	<b>Duo</b>	<b>KL750</b>
<b>375kg</b>	<b>600mm</b>	<b>600mm</b>	<b>450mm</b>	<b>Duo</b>	<b>KL375</b>
<b>1600kg</b>	<b>1830mm</b>	<b>610mm</b>	<b>610mm</b>	<b>Vee</b>	<b>KV1600</b>
<b>1333kg</b>	<b>1525mm</b>	<b>610mm</b>	<b>610mm</b>	<b>Vee</b>	<b>KV1333</b>
<b>1067kg</b>	<b>1220mm</b>	<b>610mm</b>	<b>610mm</b>	<b>Vee</b>	<b>KV1067</b>
<b>800kg</b>	<b>915mm</b>	<b>610mm</b>	<b>610mm</b>	<b>Vee</b>	<b>KV800</b>
<b>533kg</b>	<b>610mm</b>	<b>610mm</b>	<b>610mm</b>	<b>Vee</b>	<b>KV533</b>
775kg	2200mm	600mm	250mm	Solar	KZ775
1000kg	2300mm	460mm	400mm	Solar	KZ1000
1000kg	1000mm	1000mm	425mm	Cube	KC1000
1125kg	1800mm	600mm	450mm	Duo	KC1125
2000kg	1220mm	990mm	750mm	Security	KS2000
2350kg	1000mm	1000mm	1000mm	Cube	KC2350
2950kg	1000mm	1000mm	1250mm	Cube	KC2950
3000kg	1400mm	1400mm	700mm	MOD	KX3000



### Marquee blocks

1000kg

500kg

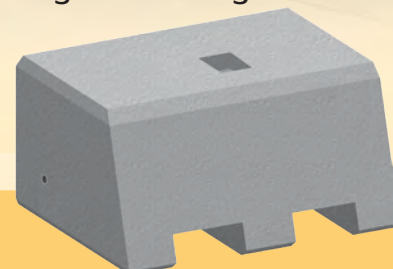
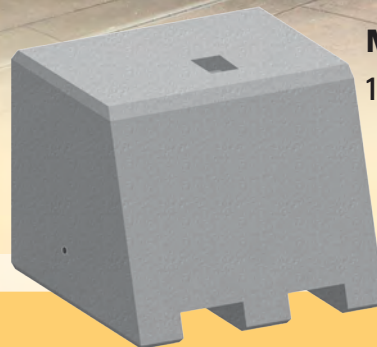

Elite Precast Concrete Limited  
 Halesfield 9, Telford, Shropshire TF7 4QW  
 Tel: 01952 588885 Fax: 01952 582011  
[www.eliteprecast.co.uk](http://www.eliteprecast.co.uk)

## Channels... Ducts... Troughs

Precast concrete ducting is a system that allows for the accommodation of a number of different services from multiple utility and building providers.

The trough and lid system has a number of distinct advantages over direct bury and overhead suspension including...

**PROVIDING A PROTECTIVE BARRIER FOR SERVICES AGAINST ACCIDENTAL DAMAGE**

**ACTING AS A CLEAR INDICATION OF UTILITY INSTALLATIONS**

**EASY ACCESS FOR MAINTENANCE AND REPAIRS**

**HIGH LEVELS OF SECURITY**

Applications include the housing/transportation of...

**Electric cables**

**Gas pipes**

**Steam pipes**

**Water**

**Sewage**

**Slurry**

**Fibre optic cables**

or multiples of the above.

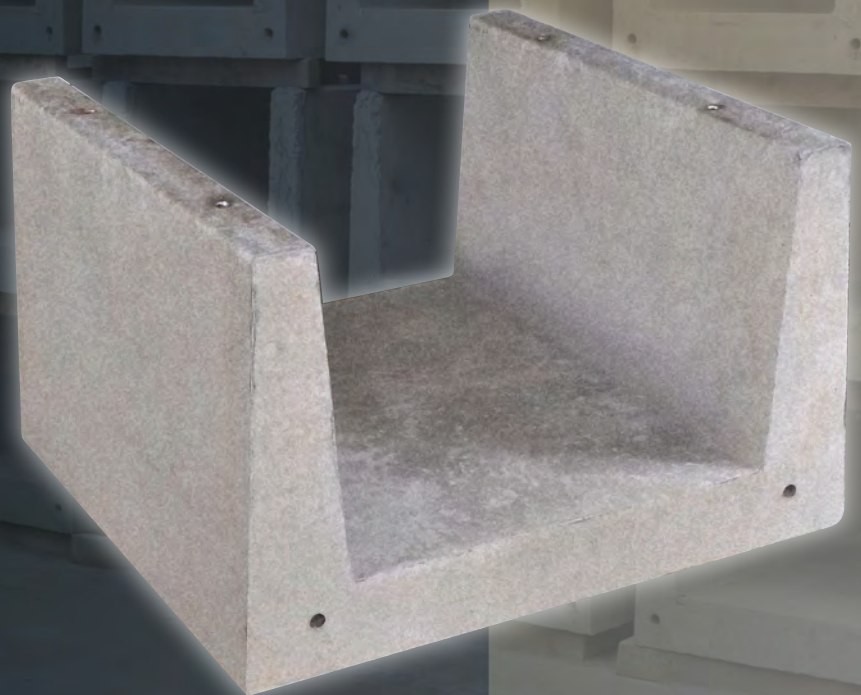

For more information on Elite quality concrete products  
phone 01952 588 885 or browse [www.eliteprecast.co.uk](http://www.eliteprecast.co.uk)

# Channels... Ducts... Troughs

## Ducts/channels

Rectangular Ducts are available in the following dimensions set out in the table below, as indicated by the key letters on the drawing illustrated right.

All lids are manufactured to withstand Highways loadings.

CAD drawings and weights of the channels can be down-loaded from the Technical Drawings section. We can also cater for bespoke sizes made to your specification.

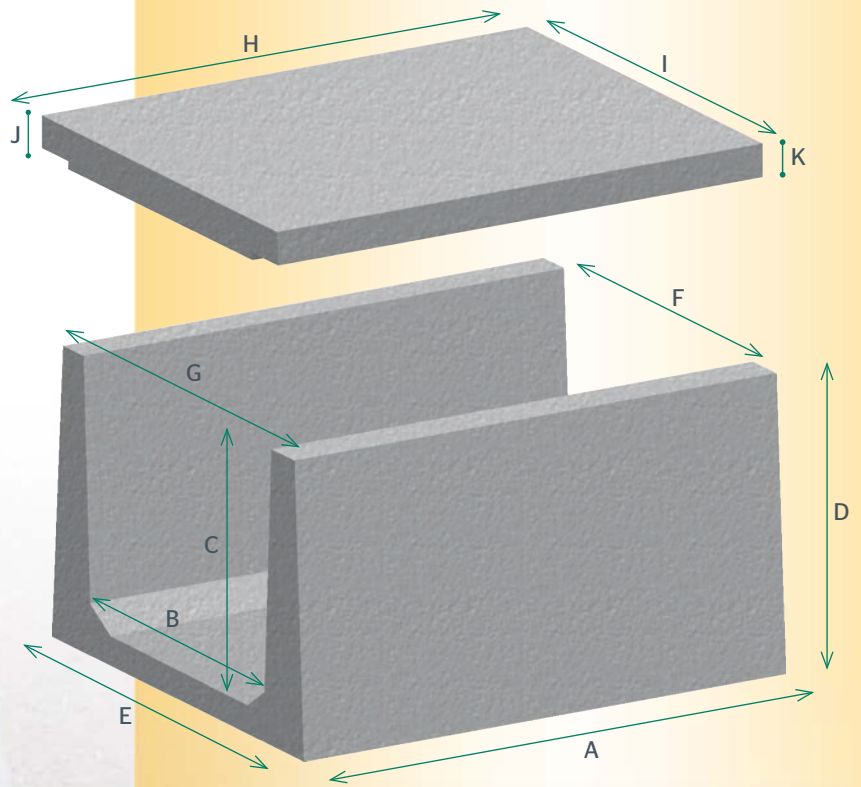

### Ducts

Ducts Code	Channel dimensions mm							Unit weight	Lids Code	Lid dimensions mm				Unit weight
	A	B	C	D	E	F	G			H	I	J	K	
5107	1500	300	300	390	470	314	454	324kg	5107	1500	475	122	102	183kg
5059	2000	600	450	575	850	700	850	955kg						
1196	1000	450	450	575	655	475	625	385kg	1197	1000	655	135	120	200kg
1603	1000	600	320	445	910	700	850	430kg	1601	1000	920	160	145	330kg
1606	1000	600	620	745	910	700	850	580kg						
1755	1000	730	520	660	1070	810	990	660kg	1701	1000	1070	160	145	380kg
1757	1000	700	770	910	1100	810	990	880kg						
1050	1000	1000	520	660	1320	1060	1240	750kg	1001	1000	1320	160	145	480kg
1075	1000	960	770	910	1350	1060	1240	960kg						
1010	1000	930	1020	1160	1380	1060	1240	1220kg						
1012	1000	1000	1200	1325	1450	1100	1350	1425kg						

## Cable Protection Covers

Concrete Cable Protection Covers, also known as Cable Route Markers, are used frequently by utility companies to provide a clear indication to site staff who may be working close to underground electrical cables.

Covers act as a protective barrier against damage to buried electricity cables eliminating the risk of accidents and costly repairs. They can also be used to locate and indentify other underground services.

Protection covers are reinforced precast concrete units manufactured and tested to BS2484 specifications. The covers are imprinted, as standard, with the words 'DANGER ELECTRICITY' and are available in three sizes.

On request, bespoke covers can be manufactured to order for other services such as Telephone, Gas, Oil, Chemicals, Fibre Optics, etc.

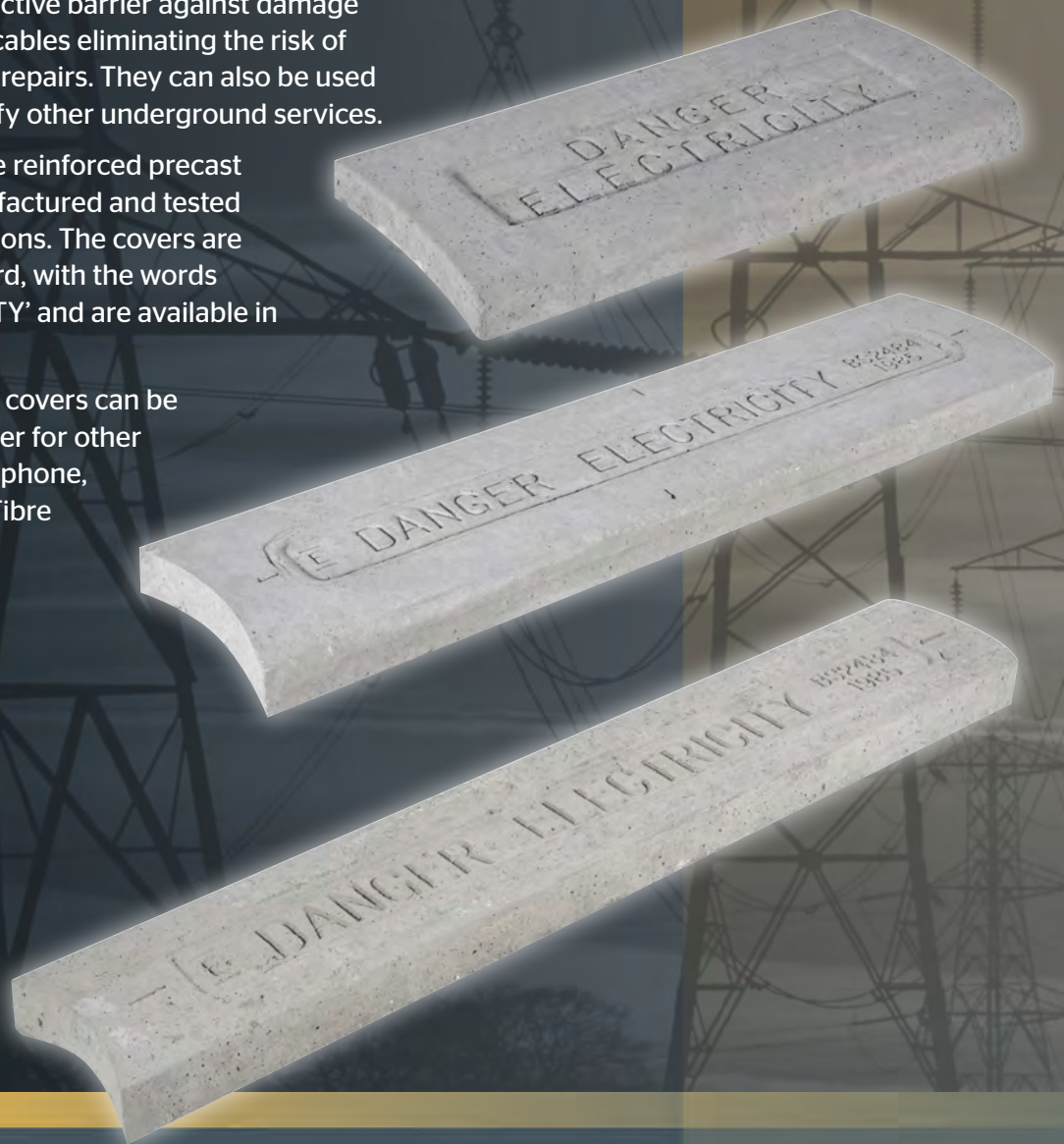

For more information on Elite quality concrete products  
phone 01952 588 885 or browse [www.eliteprecast.co.uk](http://www.eliteprecast.co.uk)

# Cable Protection Covers

## Cover types

Concrete Cable Protection Cover Tiles (also known as Cable Route Markers) are manufactured to BS 2484 and imprinted as standard with the indented lettering warning legend DANGER ELECTRICITY and the internationally recognised Danger Sign.

There are five standard sizes available as shown below. On request we can also supply a variety of wording options such as PROPANE LINE, GAS, OIL, FIBRE-OPTIC CABLE, WATER, TELEPHONE, etc.

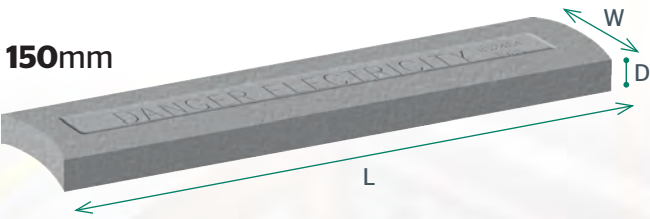

150mm



230mm



305mm medium



305mm short



## Danger Electricity

Length	Width	Depth	Weight
914mm	150mm	50mm	16kg
914mm	230mm	50mm	24kg
914mm	305mm	50mm	32kg
610mm	305mm	50mm	22kg
305mm	305mm	50mm	11kg



Elite Precast Concrete Limited  
 Halesfield 9, Telford, Shropshire TF7 4QW  
 Tel: 01952 588885 Fax: 01952 582011  
[www.eliteprecast.co.uk](http://www.eliteprecast.co.uk)

## Indicator Posts

Precast concrete indicator posts are widely used by utility companies and are installed to assist the location and identification of underground services.

Marker posts are made from reinforced precast concrete, manufactured and tested to BS 1881 standards.

They are available in a variety of types and sizes.

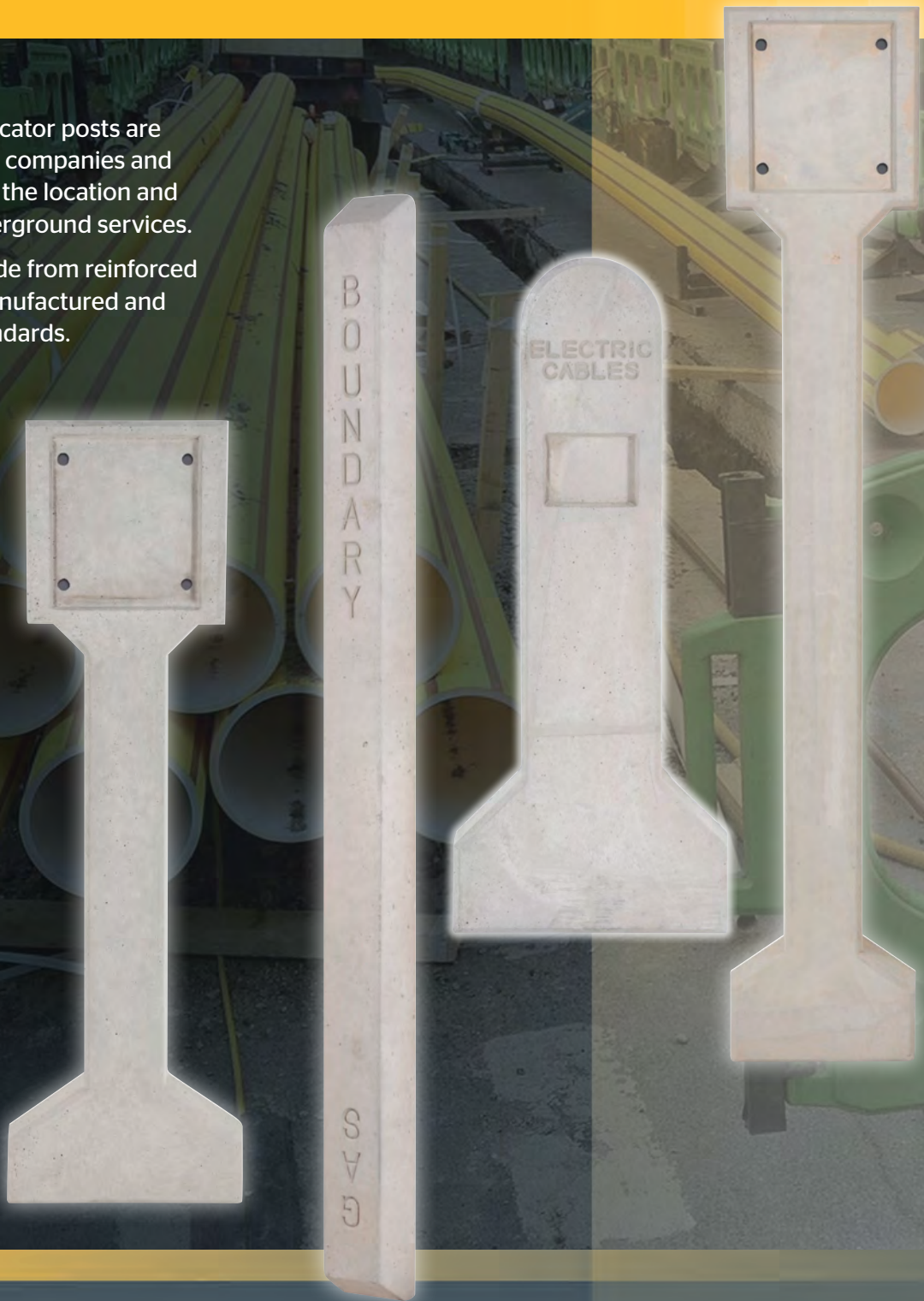

For more information on Elite quality concrete products  
phone 01952 588 885 or browse [www.eliteprecast.co.uk](http://www.eliteprecast.co.uk)

# Indicator Posts

## Post types

We manufacture several standard marker posts in accordance with BS 1881, details of which are shown in the table opposite.

Marker posts are available with or without anchor bases.

Hydrant post have preformed holes to accept plates within.

Any other requirements can be made to order.

### Marker Post

Code	Height	Width	Depth	Weight	Other Refs	Narrative
CG1	770mm	160mm	75mm	24kg	Type 2, BCP1	Electric Cables
CG1A	770mm	160mm	75mm	24kg	Type 2, BCP2	Fibre Optic Cables

### Hydrant Post

CG305A	990mm	245mm	75mm	21kg	Surrey Short, BCP8, IP4	Blank For Hydrant Plate
CG305	1220mm	245mm	75mm	26kg	Type 4, BCP3	Blank For Hydrant Plate
CG305B	1370mm	245mm	75mm	33kg	BCP7, IP4A	Blank For Hydrant Plate
CG305C	1525mm	245mm	75mm	40kg		Blank For Hydrant Plate

### Indicator Post

CG311	1525mm	100mm	100mm	34kg	BCP4, IP6/D	Duct
CG311A	1525mm	100mm	100mm	34kg	BCP4, IP6/G	Gas
CG311B	1525mm	100mm <td 100mm	34kg	BCP4, IP6/W	Water	
CG311C	1525mm	100mm	100mm	34kg	BCP4, IP6/S	Sewer
CG311D	1525mm	100mm	100mm	34kg	BCP4, IP6/B	Boundary
CG5	1525mm	100mm	100mm	34kg	BCP6	HABDY

### Triangular Indicator Post

CG4	1065mm	100mm	100mm	15kg	BCP5, IP6 TRI/W	Water
CG4A	1065mm	100mm	100mm	15kg	IP6TRI / S	Sewer
CG4B	1065mm	100mm	100mm	15kg	IP6TRI / PS	Pumped Sewer



Indicator post

Marker post with anchor



Hydrant post

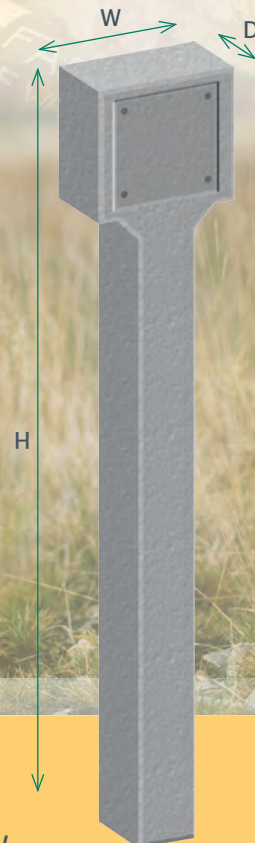



## Marker Blocks

Precast concrete marker blocks are primarily used to aid in the location and identification of electric cables and other utility services that are buried underground. They can also be used to mark boundaries and other reference points.

They are made from precast concrete and are manufactured and tested in accordance with BS 1881 standards.

Available in a range of standard sizes with various legends, however any size or wording can be produced on a bespoke basis.



For more information on Elite quality concrete products phone 01952 588 885 or browse [www.eliteprecast.co.uk](http://www.eliteprecast.co.uk)

# Marker Blocks

## Block types

Marker Blocks are manufactured in accordance with BS 1881 and standard blocks are listed in the table opposite.

Where applicable blocks have a recess on the underside which houses a 6mm galvanised bar to enable cable draw ropes etc. to be attached.

The standard recess size for identification plates is 100mm x 75mm.

Any other requirements can be made to order.

## Marker Blocks

Code	Height	Width	Depth	Weight	Other Refs	Narrative
CG2	300mm	300mm	150mm	32kg	BCB 300	Electric Cables
CG2B	300mm	300mm	150mm	32kg		High Voltage Cables
CG2C	300mm	300mm	150mm	32kg		Fibre Optic Cables
CG2D	300mm	300mm	150mm	32kg		Gas
CG2E	300mm	300mm	150mm	32kg		Water
CG2F	300mm	300mm	150mm	32kg		DHM ⇄
CG2G	300mm	300mm	150mm	32kg		Boundary
CG2H	300mm	300mm	150mm	32kg		BT
CG2J	300mm	300mm	150mm	32kg		SP
CG2A	300mm	300mm	225mm	48kg		D
CG2A	300mm	300mm	225mm	48kg		DD
CG2A	300mm	300mm	225mm	48kg		J
CG3	600mm	600mm	100mm	89kg		Electric Cables
CG4	300mm	300mm	75mm	16kg		Fire Mains
CG5	150mm	300mm	150mm	15kg		Highway Boundary
CG5A	100mm	100mm	500mm	12kg		HB

Marker block

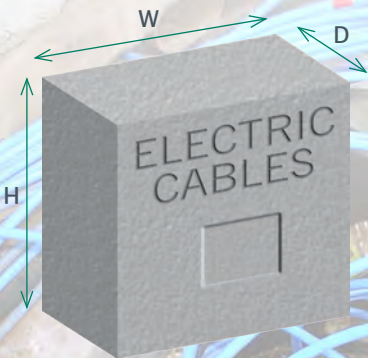

Marker slab

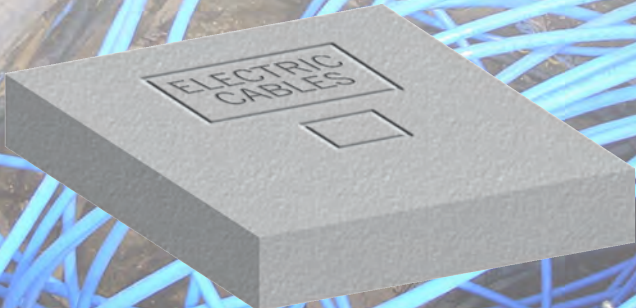

## Utility Protection Slabs

Our utility protection slabs are made from precast concrete and heavily reinforced with steel. They are designed to protect a range of vulnerable utilities such as water pipelines, high pressure gas mains and power cables from damage from above-ground traffic.

Standard slabs are 2450mm x 1000mm in area and are 200mm thick. Both faces are reinforced with heavy duty mesh and each slab weighs in at 1200kg.

Slabs can also be designed and manufactured to customer's specific requirements to any thickness.

**Protects from mechanical excavations.**

**Both faces come reinforced with heavy-duty mesh.**

**Interlocking slabs allow for easy installation and ensure rigid construction.**

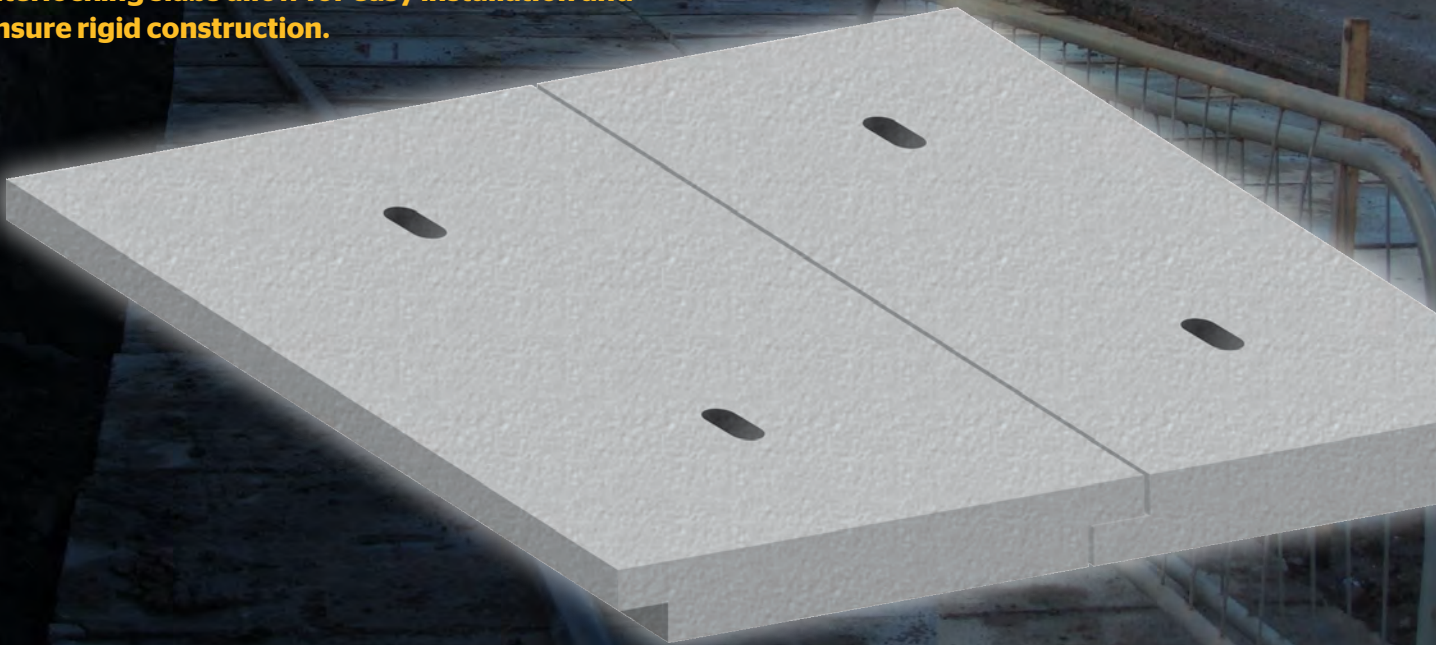

For more information on Elite quality concrete products  
phone 01952 588 885 or browse [www.eliteprecast.co.uk](http://www.eliteprecast.co.uk)

# Utility Protection Slabs

## Slab types

The standard 2450 x 1000 x 200mm slab is available off the shelf, however, protection slabs are generally made bespoke to suit customer's requirements depending on the application.

They can be manufactured to any thickness or size and incorporate suitable lifting anchors as required.

Used to protect high pressure gas mains and high voltage cables, particularly for areas vulnerable to rogue excavations.

## Utility Protection Slab

Length	Width	Depth	Weight
2450mm	1000mm	200mm	1200kg

Utility slab showing reinforcing mesh on both faces

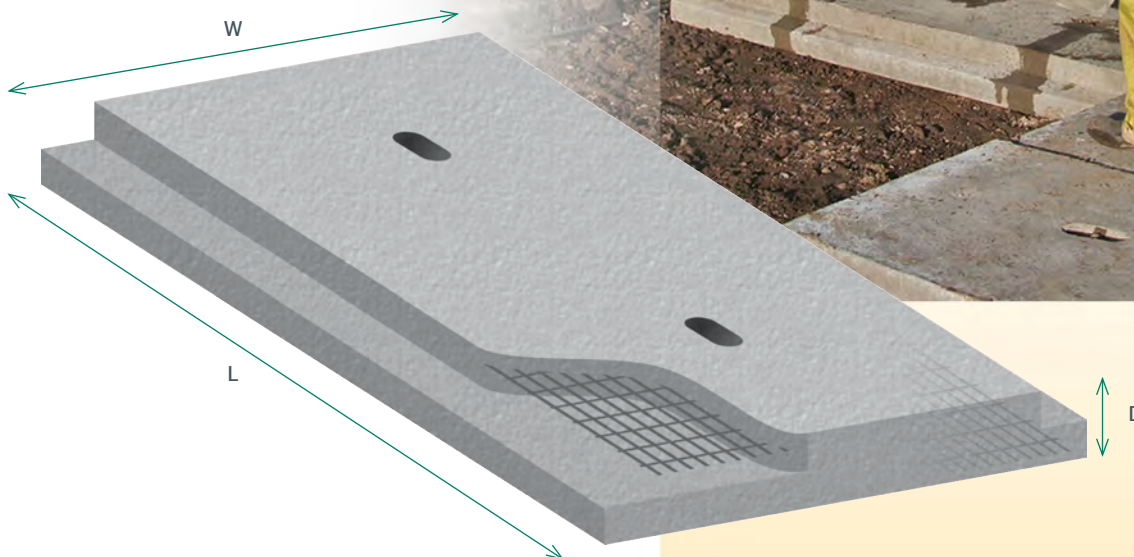

## Security Blocks

We offer a range of options when it comes to securing your premises against unwanted visitors, to manage site traffic and for use as HGV MOT test weights.

You can choose from the Security block, the Vee™ interlocking block, the Legato™ interlocking block, the Duo™ interlocking block or from our Marquee block ranges.

All systems come with integral lifting options and can be painted in your company logo/colours, Ministry of Transport approved chevrons, etc... and provide a much cheaper alternative when compared to hiring-in barriers.

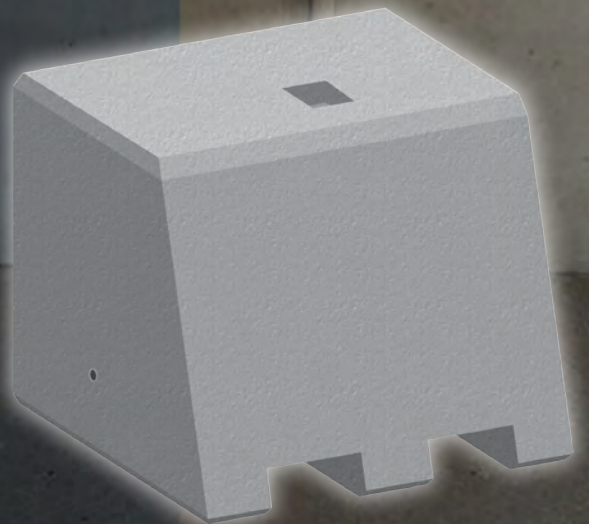

For more information on Elite quality concrete products  
phone 01952 588 885 or browse [www.eliteprecast.co.uk](http://www.eliteprecast.co.uk)

# Security Blocks

## Security Block

Our large two tonne precast concrete blocks are designed and manufactured to be used as security blocks preventing access to land and buildings and are ideal for blocking entrances and gateways or for use as HGV MOT test weights.

All of the blocks have their own lifting and placing systems and can be delivered and installed by our specialist team using the...

**Forklift/Telehandler slots**

**'Deha' lifting pin**

**'Hiab' type clamp**

### Security block

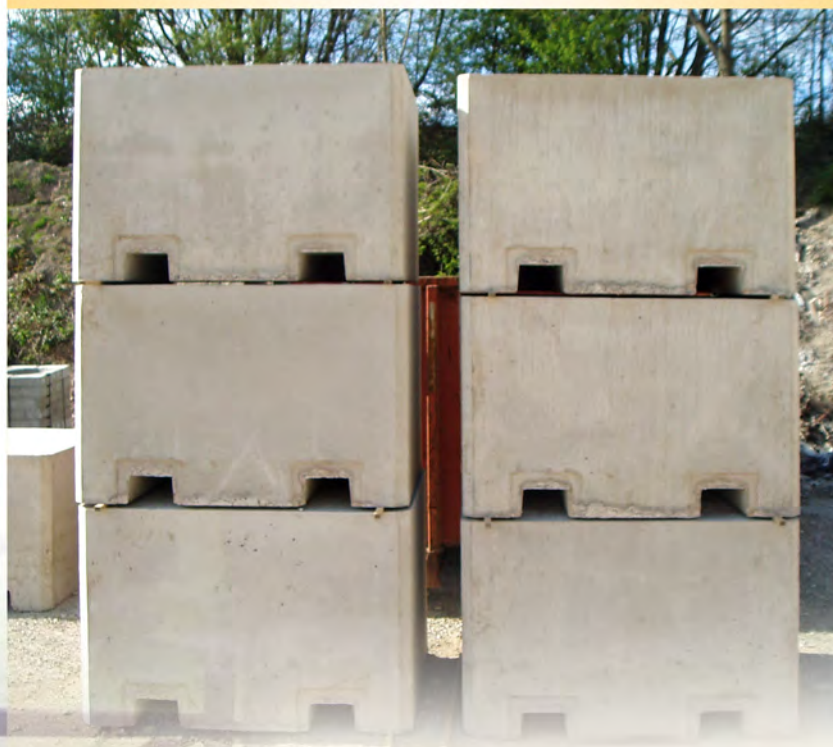
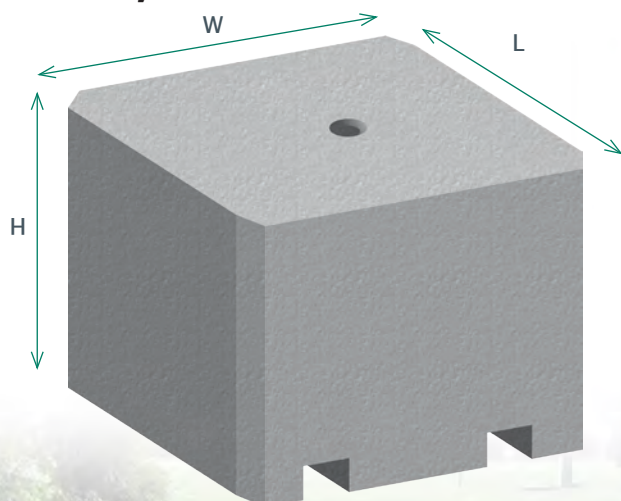

For lighter weight alternatives for the blocks listed above please refer to their respective product pages... p11 for Duo™ blocks, p13 for Legato™ blocks and p15 for Vee™ blocks.



Elite Precast Concrete Limited  
Halesfield 9, Telford, Shropshire TF7 4QW  
Tel: 01952 588885 Fax: 01952 582011  
[www.eliteprecast.co.uk](http://www.eliteprecast.co.uk)

## Jersey Barriers

The Elite Jersey barrier is an interlocking heavy duty system designed for the ultimate in anti-vehicle perimeter protection.

Cast from Elite's standard high-strength concrete (50N/mm<sup>2</sup>) the barriers are quick and easy to install and are available direct from stock for next-day nationwide delivery.

The interlocking Jersey barriers are ideal for traffic management, flood defence, site security, rockfall and edge protection.



For more information on Elite quality concrete products  
phone 01952 588 885 or browse [www.eliteprecast.co.uk](http://www.eliteprecast.co.uk)

# Jersey Barriers

## Jersey Barriers

Our Jersey barriers are 2500mm long and weigh 1450kg. The unique interlocking system provides incredible levels of security against unwanted visitors whilst allowing sections to be easily removed and repositioned should emergency access be required.

The barriers are available for delivery on a self-install basis using a standard forklift truck. Alternatively our experienced and fully-trained installation team can deliver and place them anytime, anywhere.

## Jersey Barrier

Type	Length	Width	Height	Weight
Jersey	2500mm	610mm	810mm	1450kg





# TVCBs

## Temporary Vertical Concrete Barriers

Elite's Temporary Vertical Concrete Barriers (TVCBs) are perfect for a huge variety of applications.

They are cast from Elite's highly regarded high strength concrete (50N/mm<sup>2</sup>) which, combined with approved steel reinforcing, means that the barriers meet the requirements of EN 1317 'Compliant Road Restraint Systems for Temporary Safety Barriers' (see table overleaf).



For more information on Elite quality concrete products  
phone 01952 588 885 or browse [www.eliteprecast.co.uk](http://www.eliteprecast.co.uk)

# Temporary Vertical Concrete Barriers

## TVCBs

TVCBs have a multitude of uses including...

- To create a safe working area for your workforce
- To provide flood defences
- Protecting pedestrians from traffic
- Providing traffic barriers / bases for secure fencing to be fixed to (particularly useful for large public events such as the Olympics / Commonwealth games)
- Preventing un-authorized access to forecourts, car parks, fields and site compounds
- Helping direct traffic flows safely
- As counterweights, kentledge for scaffolding, fencing, cranes, etc
- Proving security against ram raiders and terrorist attacks

The units are connected together at the scarf joint by M24 high tensile bolts.

Elite's TVCBs are always available direct from stock for nationwide next day delivery.

A crane off-load and place service is available - please call 01952 588 885 for further details.

## Temporary Vertical Concrete Barriers

Type	Overall length	Modular length	Height	Width	Weight
TCVB	3150mm	3000mm	800mm	450mm	2500kg

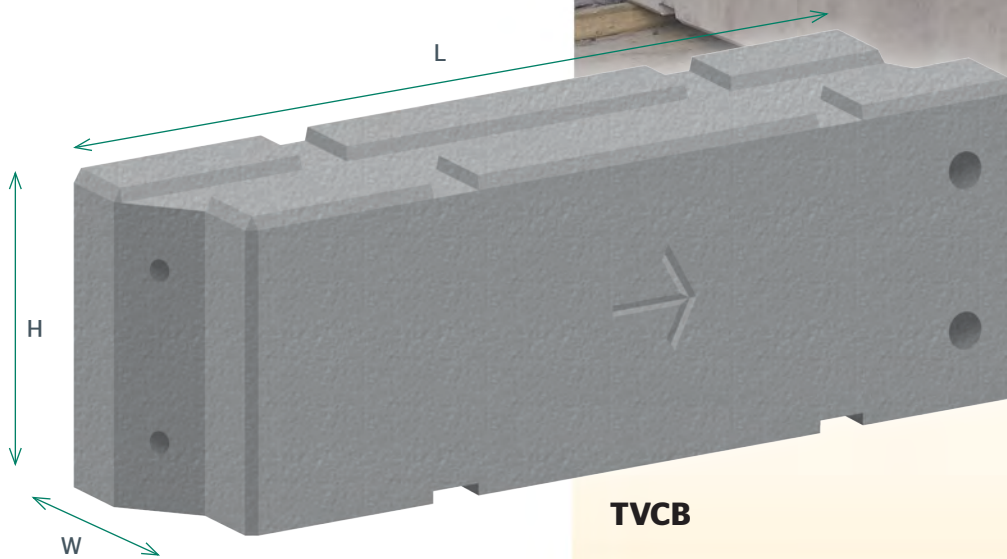

**TVCB**

## EN 1317 'Compliant Road Restraint Systems for Temporary Safety Barriers'

Containment level	Test vehicle	Test speed	Angle	Test deflection	Working width
N1	1500kg car	50mph 80kph	20deg	0.36m	W3
N2	1500kg car	70mph 110kph	20deg	0.39m	W3



Elite Precast Concrete Limited  
 Halesfield 9, Telford, Shropshire TF7 4QW  
 Tel: 01952 588885 Fax: 01952 582011  
[www.eliteprecast.co.uk](http://www.eliteprecast.co.uk)

## Seating Rings/Adjusting Units

Concrete frame adjusting/seating rings are reinforced 65mm deep units which can be used in place of engineering bricks to adjust the ductile or cast iron covers and frames to the required level.

They can be quickly and easily installed by semi-skilled labour and there are fewer joints which reduce the likelihood of infiltration.

Our multi-part adjusting units offer the advantage of light weight sections enabling one man to handle the units and comply with manual handling regulations.

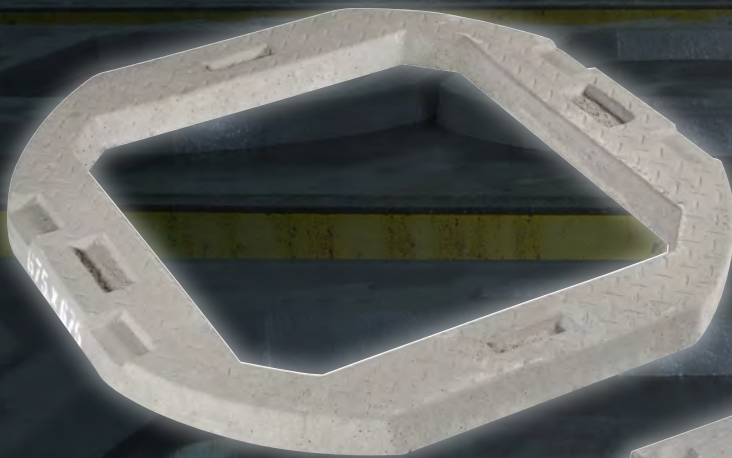

For more information on Elite quality concrete products phone 01952 588 885 or browse [www.eliteprecast.co.uk](http://www.eliteprecast.co.uk)

# Seating Rings/Adjusting Units

## Seating/adjusting types

Manhole Seating Rings are manufactured to BS 5911-3 standard in the following sizes...

### One-part Seating Rings

- 600mm x 600mm access
- 675mm x 675mm access
- 750mm x 600mm access
- 750mm x 750mm access
- 600mm x 600mm eccentric

### Two-part Seating Rings

- 600mm x 600mm access
- 675mm x 675mm access
- 1200mm x 675mm access

## Manhole seating rings

Access	Weight	Pack size	Pack weight
<b>One-part</b>			
600 x 600mm	70kg	15	1050kg
675 x 675mm	60kg	15	900kg
750 x 600mm	70kg	10	700kg
750 x 750mm	80kg	10	800kg
600 x 600mm (eccentric)	80kg	10	800kg
<b>Two-part</b>			
600 x 600mm	48kg	15	720kg
675 x 675mm	56kg	15	840kg
1200 x 675mm	90kg	10	900kg

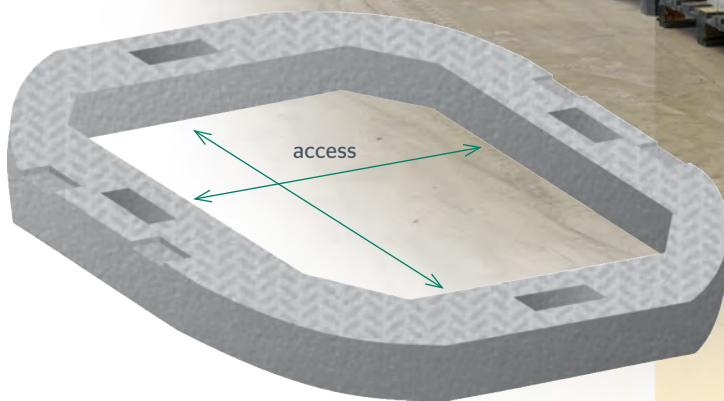

## Gully cover Slabs/Raisers

Gully cover slabs are available in both square and 'U' shaped versions, for positioning next to kerb edges, with handling recesses for lifting brackets.

They offer a cost-effective yet stronger alternative to brickwork with the added benefit of simple construction and easy fitting by semi-skilled labour.



For more information on Elite quality concrete products  
phone 01952 588 885 or browse [www.eliteprecast.co.uk](http://www.eliteprecast.co.uk)

# Gully Cover Slabs/Raisers

## Cover types

Gully cover slabs are manufactured to BS 5911-6 standard in the following sizes...

### Square shape

750mm x 650mm

### U-shape

585mm x 650mm

Thicknesses of the slabs can be either 100mm or 65mm.

## Gully cover slabs/raisers

### Square

Length	Width	Depth	Weight
750mm	650mm	100mm	78kg
750mm	650mm	65mm	50kg

### U-shape

585mm	650mm	100mm	50kg
585mm	650mm	65mm	38kg

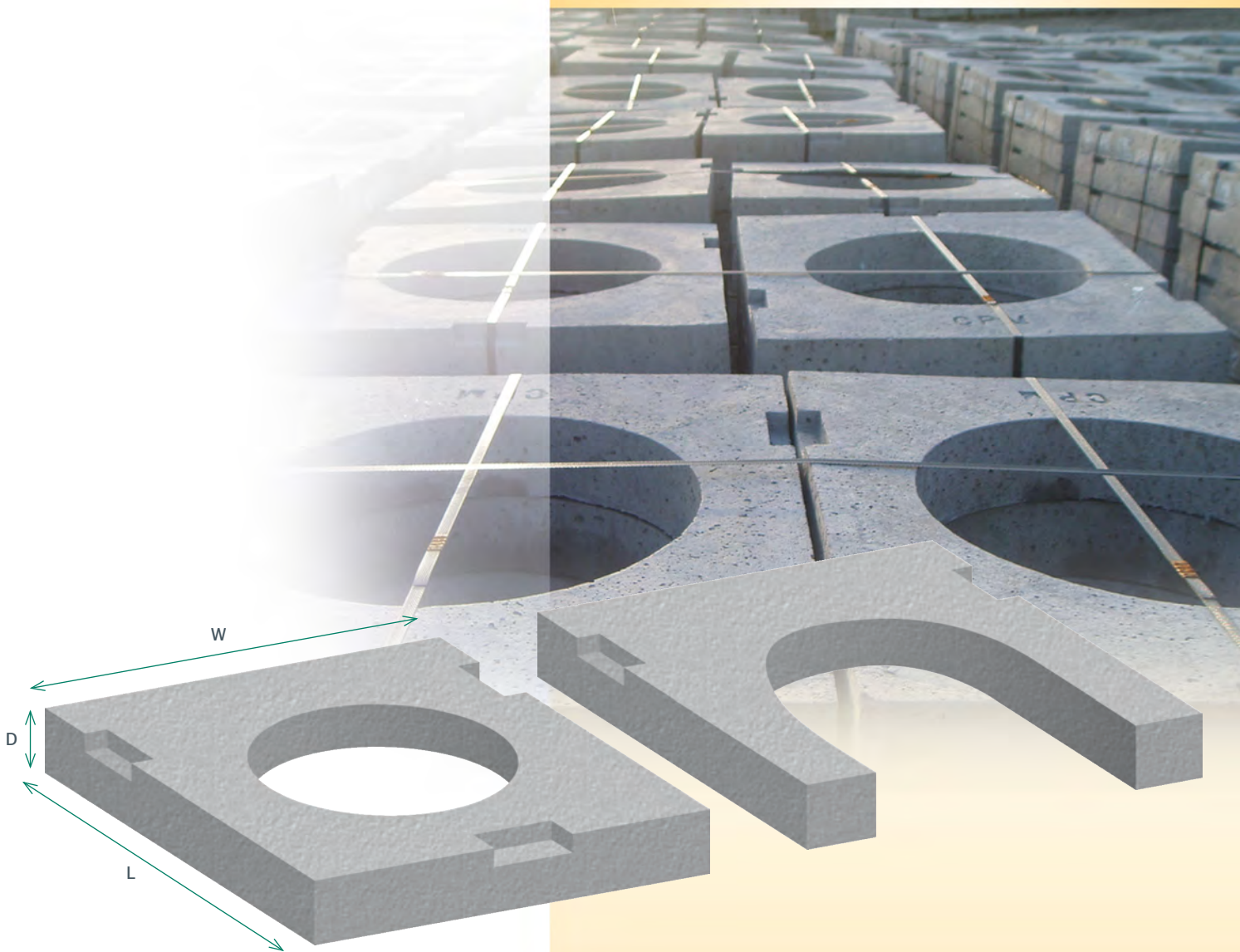

## Manhole Cover Slabs

Access hole sizes vary according to manhole diameter and depth. Elite's heavy-duty reinforced cover slabs can be supplied with a variety of standard and non-standard access hole sizes.

Designers and users should ensure that they have taken into account the current requirements for manhole access as detailed in the Health & Safety Code of Practice and other relevant requirements.



For more information on Elite quality concrete products  
phone 01952 588 885 or browse [www.eliteprecast.co.uk](http://www.eliteprecast.co.uk)

# Manhole Cover Slabs

## Slab types

Manhole Cover Slabs are manufactured to BS 5911-3 standard in the following diameters and access sizes...

### 900mm diameter

600mm x 600mm access

### 1050mm diameter

600mm x 600mm access

675mm x 675mm access

### 1200mm diameter

600mm x 600mm access

675mm x 675mm access

750mm x 600mm access

750mm x 750mm access

Lothian Seating Slabs are also available with the above access sizes.

## Manhole cover slabs

Access	Depth	Weight
--------	-------	--------

### 900mm diameter

600 x 600mm	150mm	215kg
-------------	-------	-------

### 1050mm diameter

600 x 600mm	150mm	305kg
-------------	-------	-------

675 x 675mm	150mm	265kg
-------------	-------	-------

### 1200mm diameter

600 x 600mm	150mm	445kg
-------------	-------	-------

675 x 675mm	150mm	405kg
-------------	-------	-------

750 x 600mm	150mm	405kg
-------------	-------	-------

750 x 750mm	150mm	365kg
-------------	-------	-------

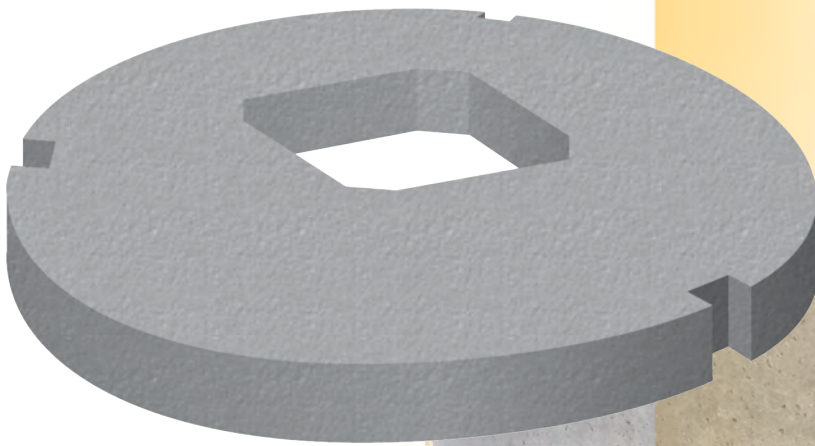

**ELITE**  
PRECAST CONCRETE

Elite Precast Concrete Limited  
Halesfield 9, Telford, Shropshire TF7 4QW  
Tel: 01952 588885 Fax: 01952 582011  
[www.eliteprecast.co.uk](http://www.eliteprecast.co.uk)



## Dam Spillway Blocks

Precast concrete wedge-shaped blocks which use the hydrodynamics of the water flow to achieve immense stability in high velocity open channel conditions such as those found on dam spillways.

The blocks are bespoke-manufactured to suit specific design and technical data.

Applications include:

**Dam overtopping**

**High velocity channels**

**Primary and secondary spillways**



For more information on Elite quality concrete products  
phone 01952 588 885 or browse [www.eliteprecast.co.uk](http://www.eliteprecast.co.uk)

# Dam Spillway Blocks

Dam Spillway Blocks are a concrete-step-overlay-protection-system for embankment dams and spillways that are subject to high forces associated with overtopping flow. The downward weight (positive force) of the block and the uplift pressure (negative force) of the flowing water allow the system to remain stable. An effective drainage network - allowing water to be removed from beneath the system - is essential to the design of the overlay.

The practicality of our Dam Spillway Blocks lies in their cost-effective ease of installation. This is particularly true for projects where the use of large machinery is deemed impractical due to confined, hard-to-reach jobsites or environmental impact on the surrounding area. Dam Spillway Blocks are typically installed over site-specific filter fabric and subsequent drainage medium on a well-compacted surface.



Elite Precast Concrete Limited  
Halesfield 9, Telford, Shropshire TF7 4QW  
Tel: 01952 588885 Fax: 01952 582011  
[www.eliteprecast.co.uk](http://www.eliteprecast.co.uk)

## Counterweight Blocks

Our security blocks, Interlocking concrete blocks and Vee™ interlocking blocks all make excellent counterweight blocks for fall arrest systems, heavy lifting equipment etc.

We are also happy to work with our clients to manufacture 'tailor-made' blocks should they be required.



For more information on Elite quality concrete products  
phone 01952 588 885 or browse [www.eliteprecast.co.uk](http://www.eliteprecast.co.uk)



Elite Precast Concrete Limited  
Halesfield 9, Telford, Shropshire TF7 4QW  
Tel: 01952 588885 Fax: 01952 582011  
[www.eliteprecast.co.uk](http://www.eliteprecast.co.uk)

## Sea Anchor Blocks

We are delighted to present our new range of Precast Concrete Sea Anchors.

Available in a wide range of sizes with a choice of galvanised steel lifting and guide hoops, with integral feet to help locate the blocks into the sea bed.

We also manufacture to suit customer requirements - please call for further information.

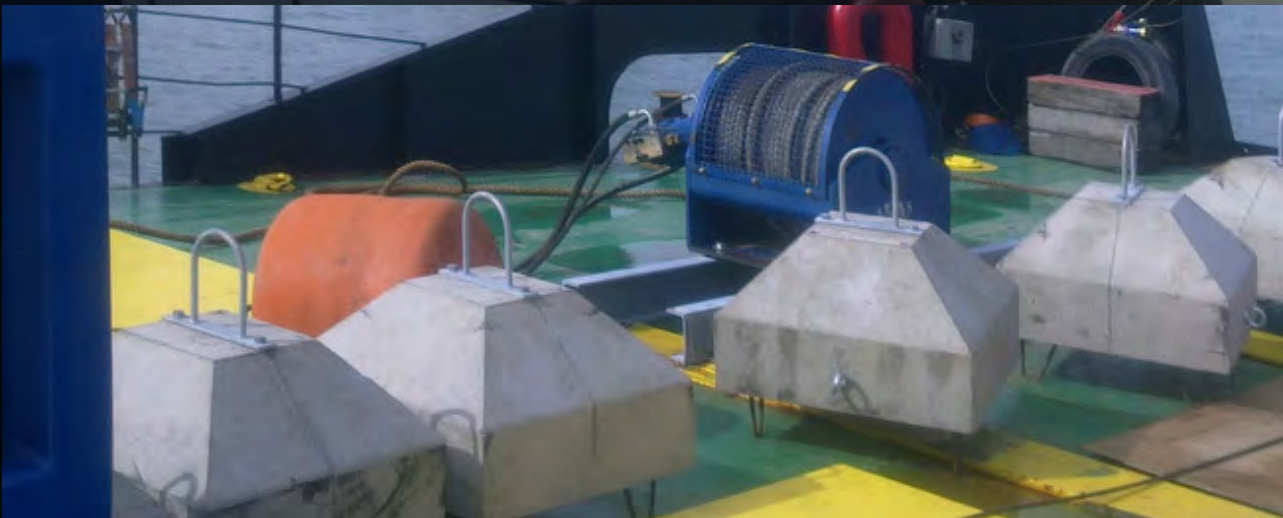

For more information on Elite quality concrete products  
phone 01952 588 885 or browse [www.eliteprecast.co.uk](http://www.eliteprecast.co.uk)



Elite Precast Concrete Limited  
Halesfield 9, Telford, Shropshire TF7 4QW  
Tel: 01952 588885 Fax: 01952 582011  
[www.eliteprecast.co.uk](http://www.eliteprecast.co.uk)

# Elite Concrete terms & conditions of sale

## 1. GENERAL

(i) All contracts for the supply of goods and/or services between Elite Precast Concrete Limited ("the Company") and yourself ("the Customer") are subject to the following terms and conditions ("the contract") which shall apply to the exclusion of any terms or conditions whatsoever whether express, implied by law or otherwise including but not limited to the terms of specification in whole or in part. You acknowledge that you have not relied on any statement, promise or representation made or given by or on behalf of the Company which is not set out in the contract. Nothing in this condition shall exclude or limit the Company's liability for fraudulent misrepresentation.

(ii) No amendment or variation of any of these terms and conditions shall be valid unless expressly agreed in writing by a duly authorised representative of the Company.

(iii) Any advice or recommendation given by the Company or its employees or agents to the Customer or its employees or agents as to the storage, application or use of the goods which is not confirmed in writing by the Company is followed or acted upon entirely at the Customer's own risk, and accordingly the Company shall not be liable for any such advice or recommendation which is not confirmed.

## 2. QUOTATION

(i) Each order or acceptance of a quotation for goods and/or services by you from the Company shall be deemed to be an offer by you to purchase goods and/or services subject to these conditions.

(ii) No quotation shall constitute an offer or tender but shall be deemed to be an invitation to treat.

(iii) Any quotation is given on the basis that no contract shall come into existence until the Company despatches an acknowledgement of order to you. Subject to clause 4(ii) any quotation is valid for a period of 60 days only from its date, provided that the Company has not previously withdrawn it.

(iv) You shall ensure that the terms of its order and any applicable specification are complete and accurate.

## 3. CONTRACT

Your written confirmation order is required prior to the date of delivery or this acknowledgement is deemed to be correct. A contract for the supply of goods or services is constituted by the despatch by the Company of its written acknowledgment of order, and the date of the contract shall be the date of the said written acknowledgment order. It is preferable for manhole orders to be accepted with completed schedules.

## 4. PRICES

(i) Unless otherwise specified in the quotation, all prices quoted are exclusive of value added tax, excise duties and import duties where applicable, and all costs or charges in relation to unloading and insurance, all of which the Customer shall pay in addition when it is due to pay for the goods or services.

(ii) Notwithstanding clause 2(iii) the Company reserves the right in its absolute and unfettered discretion to vary the price from that quoted in the event of any variation in the cost of materials, labour, services, interest rates, transport and statutory charges between the date of contract and the date of despatch.

## 5. TECHNICAL DRAWINGS ETC.

(i) All technical drawings, catalogues or manuals produced by the Company and submitted to the Customer in connection with the supply of goods or services between the company and the Customer, either prior to the formation of a contract or to the goods being delivered to the Customer shall (without prejudice to the provisions of Clause 16) be strictly adhered to by the Customer.

(ii) All quotations, drawings or technical documents submitted to the Customer prior to or subsequent to the formation of a contract remain the exclusive property of the Company and are returnable to the Company on request. They may not be used by the Customer or copied, reproduced, transmitted in any form or any means including photocopying or communicated to a third party except with the prior written consent of the Company given by a duly authorised representative of the Company.

## 6. LICENCES AND PERMITS

If the performance of any contract requires a licence or other permit of any government or authority to be granted to the Company, the Customer shall be responsible for obtaining the same and the contract shall be conditional upon such licence or permit being available at the relevant time and if it is not so available the Company shall be entitled to cancel the contract by giving the Customer written notice to that effect. Should any such licence or permit not be available at the relevant time, the Customer shall be liable for any costs or expenses incurred by the Company in the performance of the contract as a result of such delay or, where the contract is cancelled, up to the date of its cancellation.

## 7. PAYMENT

(i) Unless otherwise agreed in writing between a duly authorised representative of the Company and the Customer, payment for any goods shall be made by the Customer to the Company in pounds sterling within 30 days of the end of the month in which an invoice is delivered or deemed to be delivered.

(ii) Time for payment shall be of the essence.

(iii) No payment shall be deemed to have been received until the Company has received cleared funds.

(iv) All payments payable to the Company under the contract shall become due immediately on its termination despite any other provision.

(v) The Customer shall make all payments due under the contract in full without any deduction whether by way of set-off, counterclaim, discount, abatement or otherwise unless the Customer has a valid court order requiring an amount equal to such deduction to be paid by the Company to the Customer.

(vi) The Company reserves the right to charge the Customer interest upon any overdue payment or part thereof at the rate of 4% per annum above the base rate of The Bank of England from time to time in force until the date of actual payment.

## 8. DELIVERY

(i) Although the Company will endeavour to meet any date or time quoted or given for delivery of the goods, such date or time is an approximate estimate only. In respect of delivery time it shall not be of the essence.

(ii) Subject to the other provisions of these conditions, the Company shall not be liable for any direct, indirect or consequential loss (all three of which terms include, without limitation, pure economic loss, loss of profits,

loss of business, depletion of goodwill and similar loss) costs, damages, charges or expenses caused directly or indirectly by any delay in the delivery of the goods (even if caused by the Company's negligence), nor shall any delay entitle the Customer to terminate or rescind the contract unless such delay exceeds 180 days.

(iii) The Company reserves the right to despatch and invoice any part of an order when available.

(iv) Where the goods are to be delivered by instalments each delivery shall constitute a separate contract and any failure by the Company to delivery or any claim by the Customer in respect of any one or more instalments shall not entitle the Customer to treat the contract as a whole as repudiated.

(v) The Customer shall provide at its expense adequate and appropriate equipment and manual labour for unloading the goods.

(vi) Upon receipt of the goods the Customer, his employee or agent shall sign a delivery note provided by the Company. Such delivery note shall be confirmation by the Customer to the Company that the goods have been visually inspected and found to be satisfactory.

(vii) Pallets are charged at the current list price which is invoiced at the time of delivery and is credited on the return of the undamaged pallets within three months of delivery. The return of pallets is the responsibility of the Customer. No credit will be given for the return of undamaged pallets unless the Customer is able to produce a clear signature by one of the Company's drivers or employees on the Company's stationery acknowledging receipt of the return of the undamaged pallet.

## 9. DEMURRAGE

When the Company delivers goods to the Customer, the Customer shall unload the goods within a period of one hour from the arrival of the goods at the Customer's site or place of business. In the event of the Customer failing to do this, the Customer shall pay any additional costs incurred by the Company.

## 10. DAMAGE OR LOSS IN TRANSIT

(i) The quantity of any consignment of goods as recorded by the Company upon despatch from the Company's place of business shall be conclusive evidence of the quantity received by the Customer on delivery unless the Customer can provide conclusive evidence proving the contrary.

(ii) The Company shall not be liable in respect of any loss or damage whatsoever arising in transit or from non-delivery of goods howsoever caused unless notice in writing of the same is given to the Company within the period specified in the contract of carriage between the Company and any carrier or within one working day of the date when the goods were received or would in the ordinary course of events have been received.

(iii) Any liability of the Company for non-delivery of the goods shall be limited either (at the Company's sole discretion) to replacing the goods within a reasonable time or issuing a credit note at the pro rata contract rate against any invoice raised for such goods, or payment to the Customer of any sums received pursuant to any contract of insurance provided by the carrier.

## 11. STORAGE

(i) If the Customer fails to take delivery of the goods within 7 days of the date of notification that the goods are ready for collection or the Company is unable to deliver the goods on time because the Customer has not provided appropriate instructions, documents, licences or authorisations, if forwarding instructions are not received within 7 days after the date of notification that the goods are ready for despatch, the Customer shall arrange for storage. If the Company agrees to store the goods then

(a) risk in the goods shall pass to the Customer (including for loss or damage caused by the Company's negligence);

(b) the goods shall be deemed to have been delivered; and

(c) the Company may store the goods until delivery, whereupon the Customer shall be liable for all related costs and expenses (including, without limitation, storage and insurance).

## 12. RISK

Unless otherwise agreed in writing the moment when the risk in the good shall pass shall be determined as follows:

(i) On a "sale delivered" the risk shall pass from the Company to the Customer when the goods are despatched by the Company.

(ii) On a sale "ex- works" the risk shall pass from the Company to the Customer when the goods have been placed at the disposal of the Customer; and

(iii) Where the Company has quoted for any installation and/or fabrication of the goods on the site risk in the goods shall pass from the Company to the Customer on delivery of the goods to site.

## 13. TITLE

(i) Notwithstanding delivery and passing of the risk in the goods supplied by the Company to the Customer pursuant to clause 12 hereof the property and title in the goods shall not pass to the Customer and shall remain with the Company until the Company shall have received in cash or cleared funds payment in full of the price of the goods and all other goods agreed to be sold by the Company to the Customer for which payment is then due.

(ii) Until the property and title in the goods passes to the Customer pursuant to the provisions of sub-paragraph (i) hereof the Customer shall keep the goods as bailee of the Company and in this connection shall set aside the goods separately from other goods in the Customer's possession and ensure that the goods are carefully stored and remain identified as the property of the Company.

(iii) If at any time before the property and title in the goods passes to the Customer pursuant to the provisions of this clause 13, the Customer sells the goods or any part thereof he shall do so as bailee and shall account to the Company as agent of the Company for the proceeds of sale thereof.

(iv) The Company shall be at liberty at any time before the property and title in the goods passes to the Customer pursuant to the provisions of sub-paragraph (ii) hereof to require the goods to be returned to it and if the requirement is not immediately complied with by the Customer the Company may re-take possession thereof and may enter any premises or sites of the Customer or any other premises or sites where the goods may be for such purpose. Such return or repossession shall be without prejudice to the rights of the Company

...continued overleaf

# ...terms & conditions

to recover all sums owing by the Customer to the Company and to the Company's rights to claim damages against the Customer for the breach of any obligations on the part of the Customer arising under the contract. Any expenses incurred in such return and re-possession of the goods or any damage caused to any land and/or site by the Company in exercise of its powers hereunder shall be borne by the Customer.

(v) Until ownership of goods passes to the Customer the Company or any person nominated by it shall be entitled to enter on to the Customer's site from time to time for the purpose of:

- (a) Ensuring that the Customer has complied with the provisions of sub-paragraph (ii) hereof; and
- (b) Inspecting all books, accounts, records, documents and papers of the Customer for the purpose of determining sums due to the Company by virtue of the provisions of sub-paragraph (iii) hereof.

#### 14. TRADEMARKS, WARRANTIES AND COLOUR

(i) The Company shall be entitled to write or affix its imprint on the materials in the usual manner. Where the Company's patents, registered trademarks or copyright features are included in the design an imprint to that effect may be affixed.

(ii) Save as expressly incorporated into the Contract by a quotation or by a tender, no specification, illustration, drawing, brochure, catalogue or other information sent or made available by the Company to the Customer or any term or representation made by any servant or agent of the Company shall have any contractual effect.

(iii) No guarantee or warranty is given that these goods are designed or suitable for the purpose of which they may be intended.

(iv) Samples are only submitted as indicative of the product quoted for without any guarantee as to the colour or quality of the bulk. All quotations are made on the basis that sales are by description and not by sample, unless otherwise agreed specifically by the Company in writing.

(v) Materials are supplied subject to natural formation characteristics, colour and marking variations.

#### 15. QUALITY

(i) The Company warrants that (subject to the other provisions of these conditions) that upon delivery the goods shall be of satisfactory workmanship and materials and goods of their respective kind generally in accordance with the relevant British Standard.

(ii) The Company shall not be liable for a breach of the warranty in sub-paragraph (i) hereof unless:

(a) the Customer gives written notice of the defect to the Company, and, if the defect is as a result of damage in transit by the carrier, within 7 days of the time when the Customer discovers or ought to have discovered the defect and in any event not later than 28 days from the date of delivery; and

(b) the Company is given a reasonable opportunity after receiving the notice of examining such goods and the Customer (if asked to do so by the Company) returns such goods to the Company's place of business at the Company's cost for the examination to take place there.

(iii) The Company shall not be liable for a breach of the warranty in clause 15(i) if:

- (a) the Customer makes any further use of such goods after giving such notice; or
- (b) the defect arises because the Customer failed to follow the Company's oral or written instructions as to the storage, installation, commissioning, handling, use or maintenance of the goods or (if there are none) good trade practice; or
- (c) the Customer alters or repairs such goods without the written consent of the Company.

(iv) Subject to sub-paragraph (ii) and sub-paragraph (iii), if any of the goods do not conform with the warranty in sub-paragraph (i) hereof the Company shall at its option repair or replace such goods (or the defective part) or refund the price of such goods at the pro-rata Contract rate provided that, if the Company so requests, the Customer shall, at the Company's expense, return the goods or the part of such goods which is defective to the Company.

(v) If the Company complies with sub-paragraph (iv) hereof it shall have no further liability for a breach of the warranty in sub-paragraph (i) hereof in respect of such goods.

(vi) Any goods replaced shall belong to the Company.

#### 16. LIMITATION OF LIABILITY

(i) The Customer must always rely on its own skill and judgement and recognise good civil engineering practice in relation to the goods and shall satisfy himself that goods specified are suitable for the Customer's intended purpose.

(ii) Subject to clauses 8, 10 and 15 the following provisions set out the entire financial liability of the Company (including any liability for the acts or omissions of its employees, agents and sub-contractors) to the Customer in respect of:

- (a) any breach of these conditions;
- (b) any use made or resale by the Customer of any of the goods, or of any product incorporating any of the goods; and
- (c) any representation, statement or tortious act or omission including negligence arising under or in connection with the contract.

(iii) All warranties, conditions and other terms implied by statute or common law (save for the conditions implied by section 12 of the Sale of Goods Act 1979) are, to the fullest extent permitted by law, excluded from the contract.

(iv) Nothing in these conditions excludes or limits the liability of the Company:

- (a) for death or personal injury caused by the Company's negligence; or
- (b) under section 2(3), Consumer Protection Act 1987; or
- (c) for any matter which it would be illegal for the Company to exclude or attempt to exclude its liability; or
- (d) for fraud or fraudulent misrepresentation.

(v) Subject to sub-paragraphs (iii) and (iv) hereof:

(a) the Company's total liability in contract, tort (including negligence or breach of statutory duty), misrepresentation, restitution or otherwise, arising in connection with the performance or contemplated performance of the contract shall be limited to the contract price; and

(b) the Company shall not be liable to the Customer for any pure economic loss, loss of profit, loss of business, depletion of goodwill or otherwise, in each case whether direct, indirect or consequential, or any claims for consequential compensation whatsoever (howsoever caused) which arise out of or in connection with the contract.

(vi) The Company may assign the contract or any part of it to any person, firm or company.

It shall be the responsibility of the Customer to assume and to cover by insurance, if he so wishes, the risks which fall on the Customer through the operation of this clause or any other part of the contract.

#### 17. CANCELLATION

(i) Orders placed by the Customer cannot be cancelled in whole or in part except with the Company's consent in writing and on the terms that the Customer shall pay for the goods in full unless the Company agrees otherwise in which event the Customer shall be liable for all costs, expenses and losses of any kind suffered or incurred by the Company resulting directly or indirectly from such cancellation.

(ii) Where the Company agrees to goods being returned following a cancellation it shall be the responsibility of the Customer, at its own expense, to return all such goods at such time as may be agreed to the Company's works or such other place as the Company may specify in good condition. If the goods are not so returned the Customer shall be liable for the full cost thereof. Risk in any goods returned shall not revert to the Company until a receipt of the cancelled goods is signed by a duly authorised representative of the Company.

#### 18. SUSPENSION

In the event of the performance of any obligation accepted by the Company being prevented, delayed or in any way interfered with for any cause and/or reason whatsoever beyond the control of the Company including but not limited to:

(i) Rules, regulations, requisitions or orders of the Government, Local Authority or any other Statutory Authority, war, riot, civil disturbance, strike, industrial action short of a strike, lockout, accident, breakdown, fire or by any other cause beyond its control.

(ii) Shortage of labour or materials or non-delivery by the Company's suppliers or damage to or destruction of the whole or part of the goods.

(iii) Any failure by the Customer to comply with any of the terms and conditions hereof.

(iv) Any request or instruction by any third party, his servant or agent with whom the Customer is in contract with for the installation and testing of the goods; or

(v) Any request or instruction of the Customer, his servants or agents.

The Company may at its option suspend performance or cancel its obligations under the contract without liability for any damage or loss of any kind whatsoever resulting therefrom such suspension or cancellation being without prejudice to the Company's rights to recover all sums owing to it in respect of goods delivered at the date thereof including but not limited to loss of profit and interest.

#### 19. DEFAULT OF CUSTOMER

Should default be made by the Customer in complying with the contract, the Company at its option shall be entitled to suspend delivery until the default is made good or treat such default as a repudiation of the contract in which case the Customer shall (without prejudice to any right which the Company may have for the return of any goods or the payment of any compensation or damages by the Customer) pay the Company's reasonable charges for any costs or expenses incurred by the Company in the performance of the contract.

#### 20. INSOLVENCY

(i) The Company shall have the right to terminate this contract forthwith on the occurrence of any of the following events:-

- (a) The issue of a petition to wind up or for an administration order in relation to the Customer.
- (b) The appointment of a receiver in relation to any property or asset of the Customer.
- (c) The appointment of an administrative receiver over the customer or its undertaking.
- (d) The Customer ceasing to trade or becoming insolvent or the passing of a resolution for the voluntary winding up of the Customer; or
- (e) The issue of a petition for bankruptcy order or if the Customer shall make or offer to make any arrangement or composition with its creditors or if a statutory demand is served under the Insolvency Act 1986 or any statutory modification or re-enactment thereof or if a Trustee is appointed in relation to the Customer or if any distress or execution shall be levied upon the property or assets of the Customer or on the dishonour of any cheque or negotiable instrument drawn by the Customer.

(ii) If this Clause applies then, without prejudice to any other right or remedy available to the Company, the Company shall be entitled to cancel the contract or suspend any further deliveries under the contract without any liability to the Customer, and if any goods have been delivered under any contract between the Company and the Customer but not paid for, the price shall immediately become due and payable notwithstanding any previous agreement or arrangements to the contrary.

#### 21. COMPLIANCE

(i) No relaxation, forbearance, delay or indulgence by the Company in enforcing any of the terms and conditions of any contract shall prejudice the Company's rights to insist upon the strict compliance therewith nor shall the same constitute a waiver or an estoppel.

#### 22. GOVERNING LAW

(i) These terms and conditions of supply and any contract between the Company and the Customer are governed by and are to be construed in accordance with the Laws of England and Wales to the exclusive jurisdiction of whose Courts the Customer agrees to submit.

(ii) Unless this contract expressly provides otherwise, a person who is not a party to this contract has no right to enforce any of its terms under the Contracts (Rights of Third Parties) Act 1999 (the "Act"), and if a person who is not a party to this Agreement is stated to have the right to enforce any of its terms under the Act, the parties may rescind or vary this contract (and any documents entered into pursuant to or in connection with it) without the consent of that person.





**ELITE**  
PRECAST CONCRETE

